

REPUBLIC OF THE PHILIPPINES
METRO KIDAPAWAN WATER DISTRICT
Lanao, Kidapawan City

BIDDING DOCUMENTS

PACKAGE5-LOT B PROCUREMENT OF SUPPLY AND INSTALLATION OF DATA LOGGERS, CCTV SYSTEM AND OTHER EQUIPMENT (RE-BIDDING)

December 2020



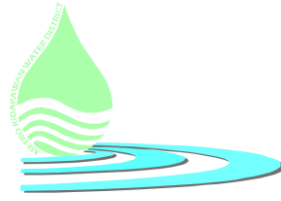

REPUBLIC OF THE PHILIPPINES
METRO KIDAPAWAN WATER DISTRICT
Lanao, Kidapawan City

BIDDING DOCUMENTS

PACKAGE 5-LOT B

PROCUREMENT OF

SUPPLY AND INSTALLATION OF DATA

LOGGERS, CCTV SYSTEM AND OTHER

EQUIPMENT

(RE-BIDDING)

Local Water Utilities Administration

Water District Development Sector Project

Issued in: December 2020

Invitation for Bids No.: WDDSP-KDP-IFB-G08e

OCB No.: WDDSP-KDP-OCB-G08e

Employer: Metro Kidapawan Water District (MKWD)

Country: Philippines



TABLE OF CONTENTS

SECTION I. INVITATION TO BID	1-1
SECTION II. INSTRUCTIONS TO BIDDERS	2-1
SECTION III. BID DATA SHEET	3-1
SECTION IV. GENERAL CONDITIONS OF CONTRACT	4-1
SECTION V. SPECIAL CONDITIONS OF CONTRACT	5-1
SECTION VI. DRAWINGS	6-1
SECTION VII. SCHEDULE OF REQUIREMENTS	7-1
SECTION VIII. TECHNICAL SPECIFICATIONS	8-1
SECTION IX. BIDDING FORMS	9-1
ANNEX A. BILL OF QUANTITIES WITH UNIT BID PRICES SET 1	
ANNEX B. BILL OF QUANTITIES WITH UNIT BID PRICES SET 2	
ANNEX C. BILL OF QUANTITIES WITH UNIT BID PRICES SET 3	

Section I. Invitation to Bid



Republic of the Philippines
METRO KIDAPAWAN WATER DISTRICT
Lanao, Kidapawan City

Tel nos. (064)577-1533, 577-1865, Fax no. (064) 572-5555

E-mail Address: metrokidapawan_wd@yahoo.com

Website: www.metrokidapawanwd.gov.ph

"Committed to Service, Development and Self-Reliance"



ISO 9001:2015 Certified
Cert. No. 66478

INVITATION TO BID PROCUREMENT OF SUPPLY AND INSTALLATION OF DATA LOGGERS, CCTV SYSTEM AND OTHER EQUIPMENT (RE-BIDDING)

1. The LOCAL WATER UTILITIES ADMINISTRATION has received a Loan from the Asian Development Bank toward the cost of the Water District Development Sector Project, and it intends to apply part of the proceeds of this loan to payments under the contract of the Procurement of Supply and Installation of Various Equipment and Facilities of Metro Kidapawan Water District for Lot B (Supply and Installation of Data Loggers, CCTV System and Other Equipment).
2. The Metro Kidapawan Water District (MKWD) now invites bids for **Package 5 Lot B**- Supply and Installation of Data Loggers, CCTV System and Other Equipment (**Set 1**- Pumps, Generator Set and Chlorine Gas Feeders, **Set 2**- Data Loggers and Other Equipment and **Set 3**- CCTV and Monitoring Equipment). Delivery of the Goods and Services is required within **ninety (90) calendar days** upon the receipt of Notice to Proceed. Bidders should have completed, within five (5) years from the date of submission and receipts of bids, a contract similar to the Project. The description of an eligible bidder is contained in the Bidding Documents, particularly, in Sub-section 5, Section II. Instructions to Bidders and the corresponding Asian Development Bank Bid Data Sheet.
3. Bidding will be conducted in accordance with relevant procedures for open competitive bidding as specified in the Implementing Rules and Regulations (IRR) of Republic Act (RA) 9184, otherwise known as the "Government Procurement Reform Act", with some amendments, as stated in these Bidding Documents and is open to all Bidders from eligible source countries as defined in the applicable procurement guidelines of the Asian Development Bank. The contract shall be awarded to the Lowest Calculated Responsive Bidder (LCRB) who was determined as such during post-qualification. The total approved budget for the contract (ABC) for **Package 5 -Lot B** is **PhP50,140,000.00** (Set 1-PhP24,350,000.00, Set 2- PhP20,600,000.00 and Set 3- PhP5,190,000.00).
4. Interested bidders may obtain further information from Metro Kidapawan Water District and inspect the Bidding Documents at the address given below during office hours, 8:00 a.m. – 5:00 p.m. except on weekends and non-working holidays.
5. A complete set of Bidding Documents may be acquired by interested Bidders on **4 December 2020** but before **02:00 p.m. of 8 January 2021** from the address below and upon payment of the applicable fee for the Bidding Documents in the amount of **PhP25,000.00**.

- Set 1 –Ten Thousand Pesos (PhP 10,000.00)
- Set 2 – Ten Thousand Pesos (PhP10,000.00)
- Set 3 –Five Thousand Pesos (PhP 5,000.00)

It may also be downloaded free of charge from the Philippine Government Electronic Procurement System (www.philgeps.gov.ph) and the MKWD (www.metrokidapawanwd.gov.ph) websites provided that Bidders shall pay the applicable fee for the Bidding Documents not later than the submission of their bids.

6. The MKWD will hold a Pre-Bid Conference on **18 December 2020, 02:00 p.m.** at the MKWD Office at the address below, which shall be open to prospective bidders. Pre-bid conference may be conducted in person or face-to-face through videoconferencing, webcasting, or similar technology, or a combination thereof.
7. Bids must be duly received by the BAC Secretariat at the address below on or before **8 January 2021, 02:00p.m.** All Bids must be accompanied by a Bid Security in any acceptable forms and in the amount stated in ITB Clause 18.1 of Section III, Bid Data Sheet.

Bid opening shall be on **8 January 2021, 02:00 p.m.** at the MKWD Office. Bids will be opened in the presence of the Bidders' representatives who choose to attend at the address below. Late bids shall not be accepted.

8. The MKWD reserves the right to accept or reject any bid, to annul the bidding process, and to reject all bids at any time prior to contract award, in accordance with ADB's Procurement Policy and Regulations, without thereby incurring any liability to the affected bidder or bidders.
9. For further information, please refer to:

SGD. CANUTO A. CODILLA, JR.
Bids and Awards Committee Secretariat
Metro Kidapawan Water District
Lanao, Kidapawan City
Telephone No.: (064) 577-3229
Email: metrokidapawan_wd@yahoo.com
Website address: www.metrokidapawanwd.gov.ph

SGD. RAMIL A. CONDEZ, CE, RMP, MBA
BAC Chairperson

Section II. Instructions to Bidders

TABLE OF CONTENTS

A. GENERAL	2-4
1. Scope of Bid	2-4
2. Source of Funds	2-4
3. Corrupt, Fraudulent, Collusive, and Coercive Practices	2-4
4. Conflict of Interest	2-5
5. Eligible Bidders	2-7
6. Bidder's Responsibilities	2-8
7. Origin of Goods	2-10
8. Subcontracts	2-10
B. CONTENTS OF BIDDING DOCUMENTS	2-11
9. Pre-Bid Conference	2-11
10. Clarification and Amendment of Bidding Documents	2-11
C. PREPARATION OF BIDS	2-12
11. Language of Bid	2-12
12. Documents Comprising the Bid: Eligibility and Technical Components	2-12
13. Documents Comprising the Bid: Financial Component	2-14
14. Alternative Bids	2-15
15. Bid Prices	2-15
16. Bid Currencies	2-17
17. Bid Validity	2-17
18. Bid Security	2-18
19. Format and Signing of Bids	2-20
20. Sealing and Marking of Bids	2-20
D. SUBMISSION AND OPENING OF BIDS	2-21
21. Deadline for Submission of Bids	2-21
22. Late Bids	2-21
23. Modification and Withdrawal of Bids	2-22
24. Opening and Preliminary Examination of Bids	2-22
E. EVALUATION AND COMPARISON OF BIDS	2-24
25. Process to be Confidential	2-24
26. Clarification of Bids	2-24
27. Domestic Preference	2-24

28. Detailed Evaluation and Comparison of Bids2-25

29. Post-Qualification.....2-26

30. Reservation Clause2-27

F. AWARD OF CONTRACT 2-28

31. Contract Award2-28

32. Signing of the Contract2-29

33. Performance Security2-30

34. Notice to Proceed2-31

35. Protest Mechanism.....2-31

A. General

1. Scope of Bid

- 1.1. The Procuring Entity named in the **BDS** invites bids for the supply and delivery of the Goods as described in
- 1.2. The name, identification, and number of lots specific to this bidding are provided in the **BDS**. The contracting strategy and basis of evaluation of lots is described in **ITB** Clause 28.

2. Source of Funds

The Procuring Entity has a budget or has received funds from the Funding Source named in the **BDS**, and in the amount indicated in the **BDS**. It intends to apply part of the funds received for the Project, as defined in the **BDS**, to cover eligible payments under the contract.

3. Corrupt, Fraudulent, Collusive, and Coercive Practices

- 3.1. Unless otherwise specified in the **BDS**, the Procuring Entity as well as the bidders and suppliers shall observe the highest standard of ethics during the procurement and execution of the contract. In pursuance of this policy, the Procuring Entity:
 - (a) defines, for purposes of this provision, the terms set forth below as follows:
 - (i) “corrupt practice” means behavior on the part of officials in the public or private sectors by which they improperly and unlawfully enrich themselves, others, or induce others to do so, by misusing the position in which they are placed, and includes the offering, giving, receiving, or soliciting of anything of value to influence the action of any such official in the procurement process or in contract execution; entering, on behalf of the government, into any contract or transaction manifestly and grossly disadvantageous to the same, whether or not the public officer profited or will profit thereby, and similar acts as provided in RA 3019.
 - (ii) “fraudulent practice” means a misrepresentation of facts in order to influence a procurement process or the execution of a contract to the detriment of the Procuring Entity, and includes collusive practices among Bidders (prior to or after bid submission) designed to establish bid prices at artificial, non-competitive levels and to deprive the Procuring Entity of the benefits of free and open competition.
 - (iii) “collusive practices” means a scheme or arrangement between two or more Bidders, with or without the knowledge of the

Procuring Entity, designed to establish bid prices at artificial, non-competitive levels.

- (iv) “coercive practices” means harming or threatening to harm, directly or indirectly, persons, or their property to influence their participation in a procurement process, or affect the execution of a contract;
- (v) “obstructive practice” is
 - (aa) deliberately destroying, falsifying, altering or concealing of evidence material to an administrative proceedings or investigation or making false statements to investigators in order to materially impede an administrative proceedings or investigation of the Procuring Entity or any foreign government/foreign or international financing institution into allegations of a corrupt, fraudulent, coercive or collusive practice; and/or threatening, harassing or intimidating any party to prevent it from disclosing its knowledge of matters relevant to the administrative proceedings or investigation or from pursuing such proceedings or investigation; or
 - (bb) acts intended to materially impede the exercise of the inspection and audit rights of the Procuring Entity or any foreign government/foreign or international financing institution herein.
- (b) will reject a proposal for award if it determines that the Bidder recommended for award has engaged in any of the practices mentioned in this Clause for purposes of competing for the contract.

3.2. Further, the Procuring Entity will seek to impose the maximum civil, administrative, and/or criminal penalties available under applicable laws on individuals and organizations deemed to be involved in any of the practices mentioned in **ITB** Clause 3.1(a).

3.3. Furthermore, the Funding Source and the Procuring Entity reserve the right to inspect and audit records and accounts of a bidder or supplier in the bidding for and performance of a contract themselves or through independent auditors as reflected in the **GCC** Clause 3.

4. Conflict of Interest

4.1. All Bidders found to have conflicting interests shall be disqualified to participate in the procurement at hand, without prejudice to the imposition of appropriate administrative, civil, and criminal sanctions. A Bidder may be considered to have conflicting interests with another Bidder in any of the events described in paragraphs (a) through (c) below and a general conflict of

interest in any of the circumstances set out in paragraphs (d) through (g) below:

- (a) A Bidder has controlling shareholders in common with another Bidder;
 - (b) A Bidder receives or has received any direct or indirect subsidy from any other Bidder;
 - (c) A Bidder has the same legal representative as that of another Bidder for purposes of this bid;
 - (d) A Bidder has a relationship, directly or through third parties, that puts them in a position to have access to information about or influence on the bid of another Bidder or influence the decisions of the Procuring Entity regarding this bidding process;
 - (e) A Bidder submits more than one bid in this bidding process. However, this does not limit the participation of subcontractors in more than one bid;
 - (f) A Bidder who participated as a consultant in the preparation of the design or technical specifications of the Goods and related services that are the subject of the bid; or
 - (g) A Bidder who lends, or temporarily seconds, its personnel to firms or organizations which are engaged in consulting services for the preparation related to procurement for or implementation of the project, if the personnel would be involved in any capacity on the same project.
- 4.2. In accordance with Section 47 of the IRR of RA 9184, all Bidding Documents shall be accompanied by a sworn affidavit of the Bidder that it is not related to the Head of the Procuring Entity (HoPE), members of the Bids and Awards Committee (BAC), members of the Technical Working Group (TWG), members of the BAC Secretariat, the head of the Project Management Office (PMO) or the end-user unit, and the project consultants, by consanguinity or affinity up to the third civil degree. On the part of the Bidder, this Clause shall apply to the following persons:
- (a) If the Bidder is an individual or a sole proprietorship, to the Bidder himself;
 - (b) If the Bidder is a partnership, to all its officers and members;
 - (c) If the Bidder is a corporation, to all its officers, directors, and controlling stockholders;
 - (d) If the Bidder is a cooperative, to all its officers, directors, and controlling shareholders or members; and

- (e) If the Bidder is a joint venture (JV), the provisions of items (a), (b), (c), or (d) of this Clause shall correspondingly apply to each of the members of the said JV, as may be appropriate.

Relationship of the nature described above or failure to comply with this Clause will result in the automatic disqualification of a Bidder.

5. Eligible Bidders

5.1. Unless otherwise provided in the **BDS**, the following persons shall be eligible to participate in this bidding:

- (a) Duly licensed Filipino citizens/sole proprietorships;
- (b) Partnerships duly organized under the laws of the Philippines and of which at least sixty percent (60%) of the interest belongs to citizens of the Philippines;
- (c) Corporations duly organized under the laws of the Philippines, and of which at least sixty percent (60%) of the outstanding capital stock belongs to citizens of the Philippines;
- (d) Cooperatives duly organized under the laws of the Philippines; and
- (e) Persons/entities forming themselves into a Joint Venture (JV), *i.e.*, a group of two (2) or more persons/entities that intend to be jointly and severally responsible or liable for a particular contract: Provided, however, that Filipino ownership or interest of the JV concerned shall be at least sixty percent(60%).

5.2. Foreign bidders may be eligible to participate when any of the following circumstances exist, as specified in the **BDS**:

- (a) When a Treaty or International or Executive Agreement as provided in Section 4 of RA 9184 and its IRR allow foreign bidders to participate;
- (b) Citizens, corporations, or associations of a country, the laws or regulations of which grant reciprocal rights or privileges to citizens, corporations, or associations of the Philippines;
- (c) When the Goods sought to be procured are not available from local suppliers; or
- (d) When there is a need to prevent situations that defeat competition or restrain trade.

5.3. Government owned or –controlled corporations (GOCCs) may be eligible to participate only if they can establish that they (a) are legally and financially autonomous, (b) operate under commercial law, and (c) are not attached agencies of the Procuring Entity.

- 5.4. Unless otherwise provided in the **BDS**, the Bidder must have completed a Single Largest Completed Contract (SLCC) similar to the Project and the value of which, adjusted, if necessary, by the Bidder to current prices using the Philippine Statistics Authority (PSA) consumer price index, must be at least equivalent to a percentage of the ABC stated in the **BDS**.

For this purpose, contracts similar to the Project shall be those described in the **BDS**, and completed within the relevant period stated in the Invitation to Bid and **ITB** Clause 12.1(a)(ii).

- 5.5. The Bidder must submit a computation of its Net Financial Contracting Capacity (NFCC), which must be at least equal to the ABC to be bid, calculated as follows:

NFCC = [(Current assets minus current liabilities) (15)] minus the value of all outstanding or uncompleted portions of the projects under ongoing contracts, including awarded contracts yet to be started, coinciding with the contract to be bid.

The values of the domestic bidder's current assets and current liabilities shall be based on the latest Audited Financial Statements submitted to the BIR.

For purposes of computing the foreign bidders' NFCC, the value of the current assets and current liabilities shall be based on their audited financial statements prepared in accordance with international financial reporting standards.

If the prospective bidder opts to submit a committed Line of Credit, it must be at least equal to ten percent (10%) of the ABC to be bid. If issued by a foreign universal or commercial bank, it shall be confirmed or authenticated by a local universal or commercial bank.

6. Bidder's Responsibilities

- 6.1. The Bidder or its duly authorized representative shall submit a sworn statement in the form prescribed in
- 6.2.
- 6.3.
- 6.4.
- 6.5. Section IX. Bidding Forms as required in **ITB** Clause 12.1(b)(iii).
- 6.6. The Bidder is responsible for the following:
- (a) Having taken steps to carefully examine all of the Bidding Documents;

- (b) Having acknowledged all conditions, local or otherwise, affecting the implementation of the contract;
- (c) Having made an estimate of the facilities available and needed for the contract to be bid, if any;
- (d) Having complied with its responsibility to inquire or secure Supplemental/Bid Bulletin(s) as provided under **ITB** Clause 10.4.
- (e) Ensuring that it is not “blacklisted” or barred from bidding by the GOP or any of its agencies, offices, corporations, or LGUs, including foreign government/foreign or international financing institution whose blacklisting rules have been recognized by the GPPB;
- (f) Ensuring that each of the documents submitted in satisfaction of the bidding requirements is an authentic copy of the original, complete, and all statements and information provided therein are true and correct;
- (g) Authorizing the HoPE or its duly authorized representative/s to verify all the documents submitted;
- (h) Ensuring that the signatory is the duly authorized representative of the Bidder, and granted full power and authority to do, execute and perform any and all acts necessary and/or to represent the Bidder in the bidding, with the duly notarized Secretary’s Certificate attesting to such fact, if the Bidder is a corporation, partnership, cooperative, or joint venture;
- (i) Complying with the disclosure provision under Section 47 of RA 9184 and its IRR in relation to other provisions of RA 3019;
- (j) Complying with existing labor laws and standards, in the case of procurement of services; Moreover, bidder undertakes to:
 - (i) Ensure the entitlement of workers to wages, hours of work, safety and health and other prevailing conditions of work as established by national laws, rules and regulations; or collective bargaining agreement; or arbitration award, if and when applicable.

In case there is a finding by the Procuring Entity or the DOLE of underpayment or non-payment of workers’ wage and wage-related benefits, bidder agrees that the performance security or portion of the contract amount shall be withheld in favor of the complaining workers pursuant to appropriate provisions of Republic Act No. 9184 without prejudice to the institution of appropriate actions under the Labor Code, as amended, and other social legislations.

- (ii) Comply with occupational safety and health standards and to correct deficiencies, if any.

In case of imminent danger, injury or death of the worker, bidder undertakes to suspend contract implementation pending clearance to proceed from the DOLE Regional Office and to comply with Work Stoppage Order; and

- (iii) Inform the workers of their conditions of work, labor clauses under the contract specifying wages, hours of work and other benefits under prevailing national laws, rules and regulations; or collective bargaining agreement; or arbitration award, if and when applicable, through posting in two (2) conspicuous places in the establishment's premises; and
- (k) Ensuring that it did not give or pay, directly or indirectly, any commission, amount, fee, or any form of consideration, pecuniary or otherwise, to any person or official, personnel or representative of the government in relation to any procurement project or activity.

Failure to observe any of the above responsibilities shall be at the risk of the Bidder concerned.

- 6.7. The Bidder is expected to examine all instructions, forms, terms, and specifications in the Bidding Documents.
- 6.8. It shall be the sole responsibility of the Bidder to determine and to satisfy itself by such means as it considers necessary or desirable as to all matters pertaining to the contract to be bid, including: (a) the location and the nature of this Project; (b) climatic conditions; (c) transportation facilities; and (d) other factors that may affect the cost, duration, and execution or implementation of this Project.
- 6.9. The Procuring Entity shall not assume any responsibility regarding erroneous interpretations or conclusions by the prospective or eligible bidder out of the data furnished by the procuring entity. However, the Procuring Entity shall ensure that all information in the Bidding Documents, including bid/supplemental bid bulletin/s issued, are correct and consistent.
- 6.10. Before submitting their bids, the Bidder is deemed to have become familiar with all existing laws, decrees, ordinances, acts and regulations of the Philippines which may affect this Project in any way.
- 6.11. The Bidder shall bear all costs associated with the preparation and submission of his bid, and the Procuring Entity will in no case be responsible or liable for those costs, regardless of the conduct or outcome of the bidding process.
- 6.12. The Bidder should note that the Procuring Entity will accept bids only from those that have paid the applicable fee for the Bidding Documents at the office indicated in the Invitation to Bid.

7. Origin of Goods

Unless otherwise indicated in the **BDS**, there is no restriction on the origin of goods other than those prohibited by a decision of the United Nations Security Council taken under Chapter VII of the Charter of the United Nations, subject to **ITB** Clause 27.1.

8. Subcontracts

- 8.1. Unless otherwise specified in the **BDS**, the Bidder may subcontract portions of the Goods to an extent as may be approved by the Procuring Entity and stated in the **BDS**. However, subcontracting of any portion shall not relieve the Bidder from any liability or obligation that may arise from the contract for this Project.
- 8.2. Subcontractors must submit the documentary requirements under **ITB** Clause 12 and comply with the eligibility criteria specified in the **BDS**. In the event that any subcontractor is found by the Procuring Entity to be ineligible, the subcontracting of such portion of the Goods shall be disallowed.
- 8.3. The Bidder may identify the subcontractor to whom a portion of the Goods will be subcontracted at any stage of the bidding process or during contract implementation. If the Bidder opts to disclose the name of the subcontractor during bid submission, the Bidder shall include the required documents as part of the technical component of its bid.

B. Contents of Bidding Documents

9. Pre-Bid Conference

- 9.1. (a) If so specified in the **BDS**, a pre-bid conference shall be held at the venue and on the date indicated therein, to clarify and address the Bidders' questions on the technical and financial components of this Project.

(b) The pre-bid conference shall be held at least twelve (12) calendar days before the deadline for the submission and receipt of bids, but not earlier than seven (7) calendar days from the posting of the invitation to bid/bidding documents in the PhilGEPS website. If the Procuring Entity determines that, by reason of the method, nature, or complexity of the contract to be bid, or when international participation will be more advantageous to the GOP, a longer period for the preparation of bids is necessary, the pre-bid conference shall be held at least thirty (30) calendar days before the deadline for the submission and receipt of bids, as specified in the **BDS**.
- 9.2. Bidders are encouraged to attend the pre-bid conference to ensure that they fully understand the Procuring Entity's requirements. Non-attendance of the Bidder will in no way prejudice its bid; however, the Bidder is expected to know the changes and/or amendments to the Bidding Documents as recorded in the minutes of the pre-bid conference and the Supplemental/Bid Bulletin. The minutes of the pre-bid conference shall be recorded and prepared not later than five (5) calendar days after the pre-bid conference. The minutes

shall be made available to prospective bidders not later than five (5) days upon written request.

- 9.3 Decisions of the BAC amending any provision of the bidding documents shall be issued in writing through a Supplemental/Bid Bulletin at least seven (7) calendar days before the deadline for the submission and receipt of bids.

10. Clarification and Amendment of Bidding Documents

- 10.1. Prospective bidders may request for clarification on and/or interpretation of any part of the Bidding Documents. Such request must be in writing and submitted to the Procuring Entity at the address indicated in the **BDS** at least ten (10) calendar days before the deadline set for the submission and receipt of Bids.
- 10.2. The BAC shall respond to the said request by issuing a Supplemental/Bid Bulletin, to be made available to all those who have properly secured the Bidding Documents, at least seven (7) calendar days before the deadline for the submission and receipt of Bids.
- 10.3. Supplemental/Bid Bulletins may also be issued upon the Procuring Entity's initiative for purposes of clarifying or modifying any provision of the Bidding Documents not later than seven (7) calendar days before the deadline for the submission and receipt of Bids. Any modification to the Bidding Documents shall be identified as an amendment.
- 10.4. Any Supplemental/Bid Bulletin issued by the BAC shall also be posted in the PhilGEPS and the website of the Procuring Entity concerned, if available, and at any conspicuous place in the premises of the Procuring Entity concerned. It shall be the responsibility of all Bidders who have properly secured the Bidding Documents to inquire and secure Supplemental/Bid Bulletins that may be issued by the BAC. However, Bidders who have submitted bids before the issuance of the Supplemental/Bid Bulletin must be informed and allowed to modify or withdraw their bids in accordance with **ITB** Clause 23.

C. Preparation of Bids

11. Language of Bids

The eligibility requirements or statements, the bids, and all other documents to be submitted to the BAC must be in English. If the eligibility requirements or statements, the bids, and all other documents submitted to the BAC are in foreign language other than English, it must be accompanied by a translation of the documents in English. The documents shall be translated by the relevant foreign government agency, the foreign government agency authorized to translate documents, or a registered translator in the foreign bidder's country; and shall be authenticated by the appropriate Philippine foreign service establishment/post or the equivalent office having jurisdiction over the foreign bidder's affairs in the Philippines. The English translation shall govern, for purposes of interpretation of the bid.

12. Documents Comprising the Bid: Eligibility and Technical Components

12.1. Unless otherwise indicated in the **BDS**, the first envelope shall contain the following eligibility and technical documents:

(a) Eligibility Documents –

Class “A” Documents:

- (i) PhilGEPS Certificate of Registration and Membership in accordance with Section 8.5.2 of the IRR, except for foreign bidders participating in the procurement by a Philippine Foreign Service Office or Post, which shall submit their eligibility documents under Section 23.1 of the IRR, provided, that the winning bidder shall register with the PhilGEPS in accordance with section 37.1.4 of the IRR.
- (ii) Statement of all its ongoing government and private contracts, including contracts awarded but not yet started, if any, whether similar or not similar in nature and complexity to the contract to be bid; and

Statement of the Bidder’s SLCC similar to the contract to be bid, in accordance with ITB Clause 5.4, within the relevant period as provided in the **BDS**.

The two statements required shall indicate for each contract the following:

- (ii.1) name of the contract;
- (ii.2) date of the contract;
- (ii.3) contract duration;
- (ii.4) owner’s name and address;
- (ii.5) kinds of Goods;
- (ii.6) For Statement of Ongoing Contracts - amount of contract and value of outstanding contracts;
- (ii.7) For Statement of SLCC - amount of completed contracts, adjusted by the Bidder to current prices using PSA’s consumer price index, if necessary for the purpose of meeting the SLCC requirement;
- (ii.8) date of delivery; and

- (ii.9) end user's acceptance or official receipt(s) or sales invoice issued for the contract, if completed, which shall be attached to the statements.
- (iii) NFCC computation in accordance with ITB Clause 5.5 or a committed Line of Credit from a universal or commercial bank.

Class "B" Document:

- (iv) If applicable, the Joint Venture Agreement (JVA) in case the joint venture is already in existence, or duly notarized statements from all the potential joint venture partners in accordance with Section 23.1(b) of the IRR.
- (b) Technical Documents –
- (i) Bid security in accordance with **ITB** Clause 18. If the Bidder opts to submit the bid security in the form of:
 - (i.1) a bank draft/guarantee or an irrevocable letter of credit issued by a foreign bank, it shall be accompanied by a confirmation from a Universal or Commercial Bank; or
 - (i.2) a surety bond, it shall be accompanied by a certification by the Insurance Commission that the surety or insurance company is authorized to issue such instruments;
 - (ii) Conformity with technical specifications, as enumerated and specified in Sections VI and VII of the Bidding Documents; and
 - (iii) Sworn statement in accordance with Section 25.3 of the IRR of RA 9184 and using the form prescribed in
 - (iv)
 - (v)
 - (vi)
 - (vii) Section IX. Bidding Forms.
 - (viii) For foreign bidders claiming eligibility by reason of their country's extension of reciprocal rights to Filipinos, a certification from the relevant government office of their country stating that Filipinos are allowed to participate in their government procurement activities for the same item or product.

13. Documents Comprising the Bid:FinancialComponent

- 13.1. Unless otherwise stated in the **BDS**, the financial component of the bid shall contain the following:
- (a) Financial Bid Form, which includes bid prices and the applicable Price Schedules, in accordance with **ITB** Clauses 15.1 and 15.4;
 - (b) If the Bidder claims preference as a Domestic Bidder, a certification from the DTI issued in accordance with **ITB** Clause 27, unless otherwise provided in the **BDS**; and
 - (c) Any other document related to the financial component of the bid as stated in the **BDS**.
- 13.2.
- (a) Unless otherwise stated in the **BDS**, all bids that exceed the ABC shall not be accepted.
 - (b) Unless otherwise indicated in the **BDS**, for foreign-funded procurement, a ceiling may be applied to bid prices provided the following conditions are met:
 - (i) Bidding Documents are obtainable free of charge on a freely accessible website. If payment of Bidding Documents is required by the procuring entity, payment could be made upon the submission of bids.
 - (ii) The procuring entity has procedures in place to ensure that the ABC is based on recent estimates made by the responsible unit of the procuring entity and that the estimates reflect the quality, supervision and risk and inflationary factors, as well as prevailing market prices, associated with the types of works or goods to be procured.
 - (iii) The procuring entity has trained cost estimators on estimating prices and analyzing bid variances.
 - (iv) The procuring entity has established a system to monitor and report bid prices relative to ABC and engineer's/procuring entity's estimate.
 - (v) The procuring entity has established a monitoring and evaluation system for contract implementation to provide a feedback on actual total costs of goods and works.

14. Alternative Bids

- 14.1 Alternative Bids shall be rejected. For this purpose, alternative bid is an offer made by a Bidder in addition or as a substitute to its original bid which may be included as part of its original bid or submitted separately therewith for purposes of bidding. A bid with options is considered an alternative bid regardless of whether said bid proposal is contained in a single envelope or submitted in two (2) or more separate bid envelopes.

- 14.2 Each Bidder shall submit only one Bid, either individually or as a partner in a JV. A Bidder who submits or participates in more than one bid (other than as a subcontractor if a subcontractor is permitted to participate in more than one bid) will cause all the proposals with the Bidder's participation to be disqualified. This shall be without prejudice to any applicable criminal, civil and administrative penalties that may be imposed upon the persons and entities concerned.

15. Bid Prices

- 15.1. The Bidder shall complete the appropriate Schedule of Prices included herein, stating the unit prices, total price per item, the total amount and the expected countries of origin of the Goods to be supplied under this Project.
- 15.2. The Bidder shall fill in rates and prices for all items of the Goods described in the Schedule of Prices. Bids not addressing or providing all of the required items in the Bidding Documents including, where applicable, Schedule of Prices, shall be considered non-responsive and, thus, automatically disqualified. In this regard, where a required item is provided, but no price is indicated, the same shall be considered as non-responsive, but specifying a zero (0) or a dash (-) for the said item would mean that it is being offered for free to the Government, except those required by law or regulations to be accomplished.
- 15.3. The terms Ex Works (EXW), Cost, Insurance and Freight (CIF), Cost and Insurance Paid to (CIP), Delivered Duty Paid (DDP), and other trade terms used to describe the obligations of the parties, shall be governed by the rules prescribed in the current edition of the International Commercial Terms (INCOTERMS) published by the International Chamber of Commerce, Paris.
- 15.4. Prices indicated on the Price Schedule shall be entered separately in the following manner:
- (a) For Goods offered from within the Procuring Entity's country:
 - (i) The price of the Goods quoted EXW (ex works, ex factory, ex warehouse, ex showroom, or off-the-shelf, as applicable);
 - (ii) The cost of all customs duties and sales and other taxes already paid or payable;
 - (iii) The cost of transportation, insurance, and other costs incidental to delivery of the Goods to their final destination; and
 - (iv) The price of other (incidental) services, if any, listed in the **BDS**.
 - (b) For Goods offered from abroad:
 - (i) Unless otherwise stated in the **BDS**, the price of the Goods shall be quoted DDP with the place of destination in the

Philippines as specified in the **BDS**. In quoting the price, the Bidder shall be free to use transportation through carriers registered in any eligible country. Similarly, the Bidder may obtain insurance services from any eligible source country.

- (ii) The price of other (incidental) services, if any, listed in the **BDS**.
 - (c) For Services, based on the form which may be prescribed by the Procuring Entity, in accordance with existing laws, rules and regulations
- 15.5. Prices quoted by the Bidder shall be fixed during the Bidder's performance of the contract and not subject to variation or price escalation on any account. A bid submitted with an adjustable price quotation shall be treated as non-responsive and shall be rejected, pursuant to **ITB** Clause 24.

All bid prices for the given scope of work in the contract as awarded shall be considered as fixed prices, and therefore not subject to price escalation during contract implementation, except under extraordinary circumstances. Upon the recommendation of the Procuring Entity, price escalation may be allowed in extraordinary circumstances as may be determined by the National Economic and Development Authority in accordance with the Civil Code of the Philippines, and upon approval by the GPPB. Nevertheless, in cases where the cost of the awarded contract is affected by any applicable new laws, ordinances, regulations, or other acts of the GOP, promulgated after the date of bid opening, a contract price adjustment shall be made or appropriate relief shall be applied on a no loss-no gain basis.

16. Bid Currencies

- 16.1. Prices shall be quoted in the following currencies:
- (a) For Goods that the Bidder will supply from within the Philippines, the prices shall be quoted in Philippine Pesos.
 - (b) For Goods that the Bidder will supply from outside the Philippines, the prices may be quoted in the currency(ies) stated in the **BDS**. However, for purposes of bid evaluation, bids denominated in foreign currencies shall be converted to Philippine currency based on the exchange rates published in the *Bangko Sentral ng Pilipinas* (BSP) reference rate bulletin on the day of the bid opening.
- 16.2. If so allowed in accordance with **ITB** Clause 16.1, the Procuring Entity for purposes of bid evaluation and comparing the bid prices will convert the amounts in various currencies in which the bid price is expressed to Philippine Pesos at the foregoing exchange rates.
- 16.3. Unless otherwise specified in the **BDS**, payment of the contract price shall be made in Philippine Pesos.

17. Bid Validity

- 17.1. Bids shall remain valid for the period specified in the **BDS** which shall not exceed one hundred twenty (120) calendar days from the date of the opening of bids.
- 17.2. In exceptional circumstances, prior to the expiration of the bid validity period, the Procuring Entity may request Bidders to extend the period of validity of their bids. The request and the responses shall be made in writing. The bid security described in **ITB** Clause 18 should also be extended corresponding to the extension of the bid validity period at the least. A Bidder may refuse the request without forfeiting its bid security, but his bid shall no longer be considered for further evaluation and award. A Bidder granting the request shall not be required or permitted to modify its bid.

18. Bid Security

- 18.1. The Bidder shall submit a Bid Securing Declaration or any form of Bid Security in the amount stated in the **BDS**, which shall be not less than the percentage of the ABC in accordance with the following schedule:

Form of Bid Security	Amount of Bid Security (Not Less than the Percentage of the ABC)
(a) Cash or cashier's/manager's check issued by a Universal or Commercial Bank. <i>For biddings conducted by LGUs, the Cashier's/Manager's Check may be issued by other banks certified by the BSP as authorized to issue such financial instrument.</i>	
(b) Bank draft/guarantee or irrevocable letter of credit issued by a Universal or Commercial Bank: Provided, however, that it shall be confirmed or authenticated by a Universal or Commercial Bank, if issued by a foreign bank. <i>For biddings conducted by LGUs, Bank Draft/Guarantee, or Irrevocable Letter of Credit may be issued by other banks certified by the BSP as authorized to issue such</i>	Two percent (2%)

Form of Bid Security	Amount of Bid Security (Not Less than the Percentage of the ABC)
<i>financial instrument.</i>	
(c) Surety bond callable upon demand issued by a surety or insurance company duly certified by the Insurance Commission as authorized to issue such security.	Five percent (5%)

The Bid Securing Declaration mentioned above is an undertaking which states, among others, that the Bidder shall enter into contract with the procuring entity and furnish the performance security required under ITB Clause 33.2, within ten (10) calendar days from receipt of the Notice of Award, and commits to pay the corresponding amount as fine, and be suspended for a period of time from being qualified to participate in any government procurement activity in the event it violates any of the conditions stated therein as provided in the guidelines issued by the GPPB.

- 18.2. The bid security should be valid for the period specified in the **BDS**. Any bid not accompanied by an acceptable bid security shall be rejected by the Procuring Entity as non-responsive.
- 18.3. No bid securities shall be returned to Bidders after the opening of bids and before contract signing, except to those that failed or declared as post-disqualified, upon submission of a written waiver of their right to file a request for reconsideration and/or protest, or upon the lapse of the reglementary period to file a request for reconsideration or protest. Without prejudice on its forfeiture, bid securities shall be returned only after the Bidder with the Lowest Calculated Responsive Bid (LCRB) has signed the contract and furnished the performance security, but in no case later than the expiration of the bid security validity period indicated in **ITB** Clause 18.2.
- 18.4. Upon signing and execution of the contract pursuant to **ITB** Clause 32, and the posting of the performance security pursuant to **ITB** Clause 33, the successful Bidder's bid security will be discharged, but in no case later than the bid security validity period as indicated in the **ITB** Clause 18.2.
- 18.5. The bid security may be forfeited:
- (a) if a Bidder:
 - (i) withdraws its bid during the period of bid validity specified in **ITB** Clause 17;

- (ii) does not accept the correction of errors pursuant to **ITB** Clause 28.3(b);
 - (iii) has a finding against the veracity of any of the documents submitted as stated in **ITB** Clause 29.2;
 - (iv) submission of eligibility requirements containing false information or falsified documents;
 - (v) submission of bids that contain false information or falsified documents, or the concealment of such information in the bids in order to influence the outcome of eligibility screening or any other stage of the public bidding;
 - (vi) allowing the use of one's name, or using the name of another for purposes of public bidding;
 - (vii) withdrawal of a bid, or refusal to accept an award, or enter into contract with the Government without justifiable cause, after the Bidder had been adjudged as having submitted the LCRB;
 - (viii) refusal or failure to post the required performance security within the prescribed time;
 - (ix) refusal to clarify or validate in writing its bid during post-qualification within a period of seven (7) calendar days from receipt of the request for clarification;
 - (x) any documented attempt by a Bidder to unduly influence the outcome of the bidding in his favor;
 - (xi) failure of the potential joint venture partners to enter into the joint venture after the bid is declared successful; or
 - (xii) all other acts that tend to defeat the purpose of the competitive bidding, such as habitually withdrawing from bidding, submitting late Bids or patently insufficient bid, for at least three (3) times within a year, except for valid reasons.
- (b) if the successful Bidder:
- (i) fails to sign the contract in accordance with **ITB** Clause 32; or
 - (ii) fails to furnish performance security in accordance with **ITB** Clause 33.

19. Format and Signing of Bids

19.1. Bidders shall submit their bids through their duly authorized representative using the appropriate forms provided in

19.2.

- 19.3.
- 19.4.
- 19.5. Section IX. Bidding Forms on or before the deadline specified in the **ITB** Clauses 21 in two (2) separate sealed bid envelopes, and which shall be submitted simultaneously. The first shall contain the technical component of the bid, including the eligibility requirements under **ITB** Clause 12.1, and the second shall contain the financial component of the bid. This shall also be observed for each lot in the case of lot procurement.
- 19.6. Forms as mentioned in **ITB** Clause 19.1 must be completed without any alterations to their format, and no substitute form shall be accepted. All blank spaces shall be filled in with the information requested.
- 19.7. The Bidder shall prepare and submit an original of the first and second envelopes as described in **ITB** Clauses 12 and 13. In addition, the Bidder shall submit copies of the first and second envelopes. In the event of any discrepancy between the original and the copies, the original shall prevail.
- 19.8. Each and every page of the Bid Form, including the Schedule of Prices, under Section VIII hereof, shall be signed by the duly authorized representative/s of the Bidder. Failure to do so shall be a ground for the rejection of the bid.
- 19.9. Any interlineations, erasures, or overwriting shall be valid only if they are signed or initialed by the duly authorized representative/s of the Bidder.

20. Sealing and Marking of Bids

- 20.1. Bidders shall enclose their original eligibility and technical documents described in **ITB** Clause 12 in one sealed envelope marked “ORIGINAL - TECHNICAL COMPONENT”, and the original of their financial component in another sealed envelope marked “ORIGINAL - FINANCIAL COMPONENT”, sealing them all in an outer envelope marked “ORIGINAL BID”.
- 20.2. Each copy of the first and second envelopes shall be similarly sealed duly marking the inner envelopes as “COPY NO. ___ - TECHNICAL COMPONENT” and “COPY NO. ___ - FINANCIAL COMPONENT” and the outer envelope as “COPY NO. ___”, respectively. These envelopes containing the original and the copies shall then be enclosed in one single envelope.
- 20.3. The original and the number of copies of the Bid as indicated in the **BDS** shall be typed or written in ink and shall be signed by the Bidder or its duly authorized representative/s.
- 20.4. All envelopes shall:
- (a) contain the name of the contract to be bid in capital letters;
 - (b) bear the name and address of the Bidder in capital letters;

- (c) be addressed to the Procuring Entity's BAC in accordance with **ITB** Clause 1.1;
 - (d) bear the specific identification of this bidding process indicated in the **ITB** Clause 1.2; and
 - (e) bear a warning "DO NOT OPEN BEFORE..." the date and time for the opening of bids, in accordance with **ITB** Clause 21.
- 20.5. Bid envelopes that are not properly sealed and marked, as required in the bidding documents, shall not be rejected, but the Bidder or its duly authorized representative shall acknowledge such condition of the bid as submitted. The BAC or the Procuring Entity shall assume no responsibility for the misplacement of the contents of the improperly sealed or marked bid, or for its premature opening.

D. Submission and Opening of Bids

21. Deadline for Submission of Bids

Bids must be received by the Procuring Entity's BAC at the address and on or before the date and time indicated in the **BDS**.

22. Late Bids

Any bid submitted after the deadline for submission and receipt of bids prescribed by the Procuring Entity, pursuant to **ITB** Clause 21, shall be declared "Late" and shall not be accepted by the Procuring Entity. The BAC shall record in the minutes of bid submission and opening, the Bidder's name, its representative and the time the late bid was submitted.

23. Modification and Withdrawal of Bids

23.1. The Bidder may modify its bid after it has been submitted; provided that the modification is received by the Procuring Entity prior to the deadline prescribed for submission and receipt of bids. The Bidder shall not be allowed to retrieve its original bid, but shall be allowed to submit another bid equally sealed and properly identified in accordance with **ITB** Clause 20, linked to its original bid marked as "TECHNICAL MODIFICATION" or "FINANCIAL MODIFICATION" and stamped "received" by the BAC. Bid modifications received after the applicable deadline shall not be considered and shall be returned to the Bidder unopened.

23.2. A Bidder may, through a Letter of Withdrawal, withdraw its bid after it has been submitted, for valid and justifiable reason; provided that the Letter of Withdrawal is received by the Procuring Entity prior to the deadline prescribed for submission and receipt of bids. The Letter of Withdrawal must be executed by the duly authorized representative of the Bidder identified in the Omnibus Sworn Statement, a copy of which should be attached to the letter.

- 23.3 Bids requested to be withdrawn in accordance with **ITB** Clause 23.1 shall be returned unopened to the Bidders. A Bidder, who has acquired the bidding documents, may also express its intention not to participate in the bidding through a letter which should reach and be stamped by the BAC before the deadline for submission and receipt of bids. A Bidder that withdraws its bid shall not be permitted to submit another bid, directly or indirectly, for the same contract.
- 23.4 No bid may be modified after the deadline for submission of bids. No bid may be withdrawn in the interval between the deadline for submission of bids and the expiration of the period of bid validity specified by the Bidder on the Financial Bid Form. Withdrawal of a bid during this interval shall result in the forfeiture of the Bidder's bid security, pursuant to **ITB** Clause 18.5, and the imposition of administrative, civil and criminal sanctions as prescribed by RA 9184 and its IRR.

24. Opening and Preliminary Examination of Bids

- 24.1. The BAC shall open the bids in public, immediately after the deadline for the submission and receipt of bids, as specified in the **BDS**. In case the Bids cannot be opened as scheduled due to justifiable reasons, the BAC shall take custody of the Bids submitted and reschedule the opening of Bids on the next working day or at the soonest possible time through the issuance of a Notice of Postponement to be posted in the PhilGEPS website and the website of the Procuring Entity concerned.
- 24.2. Unless otherwise specified in the **BDS**, the BAC shall open the first bid envelopes and determine each Bidder's compliance with the documents prescribed in **ITB** Clause 12, using a non-discretionary "pass/fail" criterion. If a Bidder submits the required document, it shall be rated "passed" for that particular requirement. In this regard, bids that fail to include any requirement or are incomplete or patently insufficient shall be considered as "failed". Otherwise, the BAC shall rate the said first bid envelope as "passed".
- 24.3. Unless otherwise specified in the **BDS**, immediately after determining compliance with the requirements in the first envelope, the BAC shall forthwith open the second bid envelope of each remaining eligible bidder whose first bid envelope was rated "passed". The second envelope of each complying bidder shall be opened within the same day. In case one or more of the requirements in the second envelope of a particular bid is missing, incomplete or patently insufficient, and/or if the submitted total bid price exceeds the ABC unless otherwise provided in **ITB** Clause 13.2, the BAC shall rate the bid concerned as "failed". Only bids that are determined to contain all the bid requirements for both components shall be rated "passed" and shall immediately be considered for evaluation and comparison.
- 24.4. Letters of Withdrawal shall be read out and recorded during bid opening, and the envelope containing the corresponding withdrawn bid shall be returned to the Bidder unopened.

- 24.5. All members of the BAC who are present during bid opening shall initial every page of the original copies of all bids received and opened.
- 24.6. In the case of an eligible foreign bidder as described in **ITB** Clause 5, the following Class “A” Documents may be substituted with the appropriate equivalent documents, if any, issued by the country of the foreign Bidder concerned, which shall likewise be uploaded and maintained in the PhilGEPS in accordance with Section 8.5.2 of the IRR:
- (a) Registration certificate from the Securities and Exchange Commission (SEC), Department of Trade and Industry (DTI) for sole proprietorship, or CDA for cooperatives;
 - (b) Mayor’s/Business permit issued by the local government where the principal place of business of the bidder is located; and
 - (c) Audited Financial Statements showing, among others, the prospective bidder’s total and current assets and liabilities stamped “received” by the Bureau of Internal Revenue or its duly accredited and authorized institutions, for the preceding calendar year which should not be earlier than two years from the date of bid submission.
- 24.7. Each partner of a joint venture agreement shall likewise submit the requirements in **ITB** Clause 12.1(a)(i). Submission of documents required under **ITB** Clauses 12.1(a)(ii) to 12.1(a)(iii) by any of the joint venture partners constitutes compliance.
- 24.8. The Procuring Entity shall prepare the minutes of the proceedings of the bid opening that shall include, as a minimum: (a) names of Bidders, their bid price (per lot, if applicable, and/or including discount, if any), bid security, findings of preliminary examination, and whether there is a withdrawal or modification; and (b) attendance sheet. The BAC members shall sign the abstract of bids as read.
- 24.8. The bidders or their duly authorized representatives may attend the opening of bids. The BAC shall ensure the integrity, security, and confidentiality of all submitted bids. The Abstract of Bids as read and the minutes of the bid opening shall be made available to the public upon written request and payment of a specified fee to recover cost of materials.
- 24.9. To ensure transparency and accurate representation of the bid submission, the BAC Secretariat shall notify in writing all bidders whose bids it has received through its PhilGEPS-registered physical address or official e-mail address. The notice shall be issued within seven (7) calendar days from the date of the bid opening.

E. Evaluation and Comparison of Bids

25. Process to be Confidential

- 25.1. Members of the BAC, including its staff and personnel, as well as its Secretariat and TWG, are prohibited from making or accepting any kind of communication with any bidder regarding the evaluation of their bids until the issuance of the Notice of Award, unless otherwise allowed in the case of **ITB** Clause 26.
- 25.2. Any effort by a bidder to influence the Procuring Entity in the Procuring Entity's decision in respect of bid evaluation, bid comparison or contract award will result in the rejection of the Bidder's bid.

26. Clarification of Bids

To assist in the evaluation, comparison, and post-qualification of the bids, the Procuring Entity may ask in writing any Bidder for a clarification of its bid. All responses to requests for clarification shall be in writing. Any clarification submitted by a Bidder in respect to its bid and that is not in response to a request by the Procuring Entity shall not be considered.

27. Domestic Preference

- 27.1. Unless otherwise stated in the **BDS**, the Procuring Entity will grant a margin of preference for the purpose of comparison of bids in accordance with the following:
 - (a) The preference shall be applied when the lowest Foreign Bid is lower than the lowest bid offered by a Domestic Bidder.
 - (b) For evaluation purposes, the lowest Foreign Bid shall be increased by fifteen percent (15%).
 - (c) In the event that the lowest bid offered by a Domestic Bidder does not exceed the lowest Foreign Bid as increased, then the Procuring Entity shall award the contract to the Domestic Bidder at the amount of the lowest Foreign Bid.
 - (d) If the Domestic Bidder refuses to accept the award of contract at the amount of the Foreign Bid within two (2) calendar days from receipt of written advice from the BAC, the Procuring Entity shall award to the bidder offering the Foreign Bid, subject to post-qualification and submission of all the documentary requirements under these Bidding Documents.
- 27.2. A Bidder may be granted preference as a Domestic Bidder subject to the certification from the DTI that the Bidder is offering unmanufactured articles, materials or supplies of the growth or production of the Philippines, or manufactured articles, materials, or supplies manufactured or to be manufactured in the Philippines substantially from articles, materials, or supplies of the growth, production, or manufacture, as the case may be, of the Philippines.

28. Detailed Evaluation and Comparison of Bids

- 28.1. The Procuring Entity will undertake the detailed evaluation and comparison of bids which have passed the opening and preliminary examination of bids, pursuant to **ITB** Clause 24, in order to determine the Lowest Calculated Bid.
- 28.2. The Lowest Calculated Bid shall be determined in two steps:
- (a) The detailed evaluation of the financial component of the bids, to establish the correct calculated prices of the bids; and
 - (b) The ranking of the total bid prices as so calculated from the lowest to the highest. The bid with the lowest price shall be identified as the Lowest Calculated Bid.
- 28.3. The Procuring Entity's BAC shall immediately conduct a detailed evaluation of all bids rated "passed," using non-discretionary pass/fail criteria. The BAC shall consider the following in the evaluation of bids:
- (a) Completeness of the bid. Unless the **BDS** allows partial bids, bids not addressing or providing all of the required items in the Schedule of Requirements including, where applicable, Schedule of Prices, shall be considered non-responsive and, thus, automatically disqualified. In this regard, where a required item is provided, but no price is indicated, the same shall be considered as non-responsive, but specifying a zero (0) or a dash (-) for the said item would mean that it is being offered for free to the Procuring Entity, except those required by law or regulations to be provided for; and
 - (b) Arithmetical corrections. Consider computational errors and omissions to enable proper comparison of all eligible bids. It may also consider bid modifications. Any adjustment shall be calculated in monetary terms to determine the calculated prices.
- 28.4. Based on the detailed evaluation of bids, those that comply with the above-mentioned requirements shall be ranked in the ascending order of their total calculated bid prices, as evaluated and corrected for computational errors, discounts and other modifications, to identify the Lowest Calculated Bid. Total calculated bid prices, as evaluated and corrected for computational errors, discounts and other modifications, which exceed the ABC shall not be considered, unless otherwise indicated in the **BDS**.
- 28.5. The Procuring Entity's evaluation of bids shall be based on the bid price quoted in the Bid Form, which includes the Schedule of Prices.
- 28.6. Bids shall be evaluated on an equal footing to ensure fair competition. For this purpose, all bidders shall be required to include in their bids the cost of all taxes, such as, but not limited to, value added tax (VAT), income tax, local taxes, and other fiscal levies and duties which shall be itemized in the bid form and reflected in the detailed estimates. Such bids, including said taxes, shall be the basis for bid evaluation and comparison.

- 28.7. If so indicated pursuant to **ITB** Clause 1.2, Bids are being invited for individual lots or for any combination thereof, provided that all Bids and combinations of Bids shall be received by the same deadline and opened and evaluated simultaneously so as to determine the Bid or combination of Bids offering the lowest calculated cost to the Procuring Entity. Bid prices quoted shall correspond to all items specified for each lot and to all quantities specified for each item of a lot. Bid Security as required by **ITB** Clause 18 shall be submitted for each contract (lot) separately. The basis for evaluation of lots is specified in BDS Clause 28.3.

29. Post-Qualification

- 29.1. The BAC shall determine to its satisfaction whether the Bidder that is evaluated as having submitted the Lowest Calculated Bid complies with and is responsive to all the requirements and conditions specified in **ITB** Clauses 5, 12, and 13.
- 29.2. Within a non-extendible period of five (5) calendar days from receipt by the bidder of the notice from the BAC that it submitted the Lowest Calculated Bid, the Bidder shall submit its latest income and business tax returns filed and paid through the BIR Electronic Filing and Payment System (eFPS) and other appropriate licenses and permits required by law and stated in the **BDS**.
- Failure to submit any of the post-qualification requirements on time, or a finding against the veracity thereof, shall disqualify the bidder for award. Provided in the event that a finding against the veracity of any of the documents submitted is made, it shall cause the forfeiture of the bid security in accordance with Section 69 of the IRR of RA 9184.
- 29.3. The determination shall be based upon an examination of the documentary evidence of the Bidder's qualifications submitted pursuant to **ITB** Clauses 12 and 13, as well as other information as the Procuring Entity deems necessary and appropriate, using a non-discretionary "pass/fail" criterion, which shall be completed within a period of twelve (12) calendar days.
- 29.4. If the BAC determines that the Bidder with the Lowest Calculated Bid passes all the criteria for post-qualification, it shall declare the said bid as the LCRB, and recommend to the HoPE the award of contract to the said Bidder at its submitted price or its calculated bid price, whichever is lower.
- 29.5. A negative determination shall result in rejection of the Bidder's Bid, in which event the Procuring Entity shall proceed to the next Lowest Calculated Bid with a fresh period to make a similar determination of that Bidder's capabilities to perform satisfactorily. If the second Bidder, however, fails the post qualification, the procedure for post qualification shall be repeated for the Bidder with the next Lowest Calculated Bid, and so on until the LCRB is determined for recommendation for contract award.
- 29.6. Within a period not exceeding fifteen (15) calendar days from the determination by the BAC of the LCRB and the recommendation to award the

contract, the HoPE or his duly authorized representative shall approve or disapprove the said recommendation.

- 29.7. In the event of disapproval, which shall be based on valid, reasonable, and justifiable grounds as provided for under Section 41 of the IRR of RA 9184, the HoPE shall notify the BAC and the Bidder in writing of such decision and the grounds for it. When applicable, the BAC shall conduct a post-qualification of the Bidder with the next Lowest Calculated Bid. A request for reconsideration may be filed by the bidder with the HoPE in accordance with Section 37.1.3 of the IRR of RA 9184.

30. Reservation Clause

- 30.1. Notwithstanding the eligibility or post-qualification of a Bidder, the Procuring Entity concerned reserves the right to review its qualifications at any stage of the procurement process if it has reasonable grounds to believe that a misrepresentation has been made by the said Bidder, or that there has been a change in the Bidder's capability to undertake the project from the time it submitted its eligibility requirements. Should such review uncover any misrepresentation made in the eligibility and bidding requirements, statements or documents, or any changes in the situation of the Bidder which will affect its capability to undertake the project so that it fails the preset eligibility or bid evaluation criteria, the Procuring Entity shall consider the said Bidder as ineligible and shall disqualify it from submitting a bid or from obtaining an award or contract.
- 30.2. Based on the following grounds, the Procuring Entity reserves the right to reject any and all bids, declare a Failure of Bidding at any time prior to the contract award, or not to award the contract, without thereby incurring any liability, and make no assurance that a contract shall be entered into as a result of the bidding:
- (a) If there is *prima facie* evidence of collusion between appropriate public officers or employees of the Procuring Entity, or between the BAC and any of the Bidders, or if the collusion is between or among the bidders themselves, or between a Bidder and a third party, including any act which restricts, suppresses or nullifies or tends to restrict, suppress or nullify competition;
 - (b) If the Procuring Entity's BAC is found to have failed in following the prescribed bidding procedures; or
 - (c) For any justifiable and reasonable ground where the award of the contract will not redound to the benefit of the GOP as follows:
 - (i) If the physical and economic conditions have significantly changed so as to render the project no longer economically, financially or technically feasible as determined by the HoPE;
 - (ii) If the project is no longer necessary as determined by the HoPE; and

- (iii) If the source of funds for the project has been withheld or reduced through no fault of the Procuring Entity.
- 30.3. In addition, the Procuring Entity may likewise declare a failure of bidding when:
- (a) No bids are received;
 - (b) All prospective Bidders are declared ineligible;
 - (c) All bids fail to comply with all the bid requirements or fail post-qualification; or
 - (d) The bidder with the LCRB refuses, without justifiable cause to accept the award of contract, and no award is made in accordance with Section 40 of the IRR of RA 9184.

F. Award of Contract

31. Contract Award

- 31.1. Subject to **ITB** Clause 29, the HoPE or its duly authorized representative shall award the contract to the Bidder whose bid has been determined to be the LCRB.
- 31.2. Prior to the expiration of the period of bid validity, the Procuring Entity shall notify the successful Bidder in writing that its bid has been accepted, through a Notice of Award duly received by the Bidder or its representative personally or sent by registered mail or electronically, receipt of which must be confirmed in writing within two (2) days by the Bidder with the LCRB and submitted personally or sent by registered mail or electronically to the Procuring Entity.
- 31.3. Notwithstanding the issuance of the Notice of Award, award of contract shall be subject to the following conditions:
- (a) Submission of the following documents within ten (10) calendar days from receipt of the Notice of Award:
 - (i) Valid JVA, if applicable; or
 - (ii) In the case of procurement by a Philippine Foreign Service Office or Post, the PhilGEPS Registration Number of the winning foreign Bidder;
 - (b) Posting of the performance security in accordance with **ITB** Clause 33;
 - (c) Signing of the contract as provided in **ITB** Clause 32; and
 - (d) Approval by higher authority, if required, as provided in Section 37.3 of the IRR of RA 9184.

- 31.4. At the time of contract award, the Procuring Entity shall not increase or decrease the quantity of goods originally specified in
- 31.5.
- 31.6.
- 31.7.
- 31.8.
- 31.9.
- 31.10. Section VI. .

32. Signing of the Contract

- 32.1. At the same time as the Procuring Entity notifies the successful Bidder that its bid has been accepted, the Procuring Entity shall send the Contract Form to the Bidder, which contract has been provided in the Bidding Documents, incorporating therein all agreements between the parties.
- 32.2. Within ten (10) calendar days from receipt of the Notice of Award, the successful Bidder shall post the required performance security, sign and date the contract and return it to the Procuring Entity.
- 32.3. The Procuring Entity shall enter into contract with the successful Bidder within the same ten (10) calendar day period provided that all the documentary requirements are complied with.
- 32.4. The following documents shall form part of the contract:
 - (a) Contract Agreement;
 - (b) Bidding Documents;
 - (c) Winning bidder's bid, including the Technical and Financial Proposals, and all other documents/statements submitted (*e.g.*, bidder's response to request for clarifications on the bid), including corrections to the bid, if any, resulting from the Procuring Entity's bid evaluation;
 - (d) Performance Security;
 - (e) Notice of Award of Contract; and
 - (f) Other contract documents that may be required by existing laws and/or specified in the **BDS**.

33. Performance Security

- 33.1. To guarantee the faithful performance by the winning Bidder of its obligations under the contract, it shall post a performance security within a maximum

period of ten (10) calendar days from the receipt of the Notice of Award from the Procuring Entity and in no case later than the signing of the contract.

- 33.2. The Performance Security shall be denominated in Philippine Pesos and posted in favor of the Procuring Entity in an amount not less than the percentage of the total contract price in accordance with the following schedule:

Form of Performance Security	Amount of Performance Security (Not less than the Percentage of the Total Contract Price)
<p>(a) Cash or cashier's/manager's check issued by a Universal or Commercial Bank.</p> <p><i>For biddings conducted by the LGUs, the Cashier's/Manager's Check may be issued by other banks certified by the BSP as authorized to issue such financial instrument.</i></p>	
<p>(b) Bank draft/guarantee or irrevocable letter of credit issued by a Universal or Commercial Bank: Provided, however, that it shall be confirmed or authenticated by a Universal or Commercial Bank, if issued by a foreign bank.</p> <p><i>For biddings conducted by the LGUs, the Bank Draft/Guarantee or Irrevocable Letter of Credit may be issued by other banks certified by the BSP as authorized to issue such financial instrument.</i></p>	<p>Five percent (5%)</p>
<p>(c) Surety bond callable upon demand issued by a surety or insurance company duly certified by the Insurance Commission as authorized to issue such security.</p>	<p>Thirty percent (30%)</p>

- 33.3. Failure of the successful Bidder to comply with the above-mentioned requirement shall constitute sufficient ground for the annulment of the award and forfeiture of the bid security, in which event the Procuring Entity shall have a fresh period to initiate and complete the post qualification of the second

Lowest Calculated Bid. The procedure shall be repeated until the LCRB is identified and selected for recommendation of contract award. However if no Bidder passed post-qualification, the BAC shall declare the bidding a failure and conduct a re-bidding with re-advertisement, if necessary.

34. Notice to Proceed

Within seven (7) calendar days from the date of approval of the contract by the appropriate government approving authority, the Procuring Entity shall issue the Notice to Proceed (NTP) together with a copy or copies of the approved contract to the successful Bidder. All notices called for by the terms of the contract shall be effective only at the time of receipt thereof by the successful Bidder.

35. Protest Mechanism

Decisions of the procuring entity at any stage of the procurement process may be questioned in accordance with Section 55 of the IRR of RA 9184.

Section III. Bid Data Sheet

Bid Data Sheet

ITB Clause	
1.1	The Procuring Entity is: Metro Kidapawan Water District (MKWD)
1.2	<p>The lot and reference are:</p> <p style="text-align: center;">Lot B: Supply and Installation of Data Loggers, CCTV System and Other Equipment</p> <p style="text-align: center;">Set 1-Pumps, Generator Set and Chlorine Gas Feeders Set 2- Data Loggers and Other Equipment Set 3- CCTV and Monitoring Equipment</p> <p>Reference: WDDSP-MKWD-OCB-G08e</p>
2	<p>The Funding Source is the Asian Development Bank (ADB) through Loan No 3389-PHI.</p> <p>The name of the Project is: Water District Development Sector Project</p> <p>Payments by the Foreign Funding Source will be made only at the request of the Procuring Entity and upon approval by the Executing Agency, Local Water Utilities Administration, in accordance with the terms and conditions of Loan No. 3389-PHI hereinafter called the "Financing Agreement," and will be subject in all respect to the terms and conditions of that Financing Agreement and the applicable law. No party other than the Procuring Entity shall derive any rights from the Financing Agreement or have any claim to the funds.</p>
3.1	<p>ADB's Anticorruption Policy requires Borrowers (including beneficiaries of ADB-financed activity), as well as Bidders, Suppliers, and Contractors under ADB-financed contracts, observe the highest standard of ethics during the procurement and execution of such contracts. In pursuance of this policy, ADB</p> <p>(a) defines, for the purposes of this provision, the terms set forth below as follows:</p> <p style="padding-left: 40px;">(i) "corrupt practice" means the offering, giving, receiving, or soliciting, directly or indirectly, anything of value to influence improperly the actions of another party;</p> <p style="padding-left: 40px;">(ii) "fraudulent practice" means any act or omission, including a misrepresentation, that knowingly or recklessly misleads, or attempts to mislead, a party to obtain a financial or other benefit or to avoid an obligation;</p> <p style="padding-left: 40px;">(iii) "coercive practice" means impairing or harming, or</p>

ITB Clause	
	<p>threatening to impair or harm, directly or indirectly, any party or the property of the party to influence improperly the actions of a party;</p> <p>(iv) “collusive practice” means an arrangement between two or more parties designed to achieve an improper purpose, including influencing improperly the actions of another party;</p> <p>(v) “obstructive practice” means (a) deliberately destroying, falsifying, altering, or concealing of evidence material to an ADB investigation; (b) making false statements to investigators in order to materially impede an ADB investigation; (c) failing to comply with requests to provide information, documents or records in connection with an Office of Anticorruption and Integrity (OAI) investigation; (d) threatening, harassing, or intimidating any party to prevent it from disclosing its knowledge of matters relevant to the investigation or from pursuing the investigation; or (e) materially impeding ADB’s contractual rights of audit or access to information; and</p> <p>(vi) “integrity violation” is any act which violates ADB’s Anticorruption Policy, including (i) to (v) above and the following: abuse, conflict of interest, violations of ADB sanctions, retaliation against whistleblowers or witnesses, and other violations of ADB's Anticorruption Policy, including failure to adhere to the highest ethical standard.</p> <p>(b) will reject a proposal for award if it determines that the Bidder recommended for award has, directly or through an agent, engaged in corrupt, fraudulent, collusive, coercive, or obstructive practices or other integrity violations in competing for the Contract;</p> <p>(c) will cancel the portion of the financing allocated to a contract if it determines at any time that representatives of the borrower or of a beneficiary of ADB-financing engaged in corrupt, fraudulent, collusive, coercive, or obstructive practices or other integrity violations during the procurement or the execution of that contract, without the borrower having taken timely and appropriate action satisfactory to ADB to remedy the situation;</p> <p>(d) will impose remedial actions on a firm or an individual, at any time, in accordance with ADB’s Anticorruption Policy and Integrity Principles and Guidelines (both as amended from time to time), including declaring ineligible, either indefinitely or for a stated period of time, to participate in ADB-financed, administered, or supported activities or to benefit from an ADB-financed, administered, or supported contract, financially or otherwise, if it at any time determines that the firm or individual has, directly or</p>

ITB Clause	
	<p>through an agent, engaged in corrupt, fraudulent, collusive, coercive, or obstructive practices or other integrity violations; and</p> <p>(e) will have the right to require that a provision be included in bidding documents and in contracts financed by ADB, requiring Bidders, suppliers and contractors to permit ADB or its representative to inspect their accounts and records and other documents relating to the bid submission and contract performance and to have them audited by auditors appointed by ADB.</p>
5.1	<p>Eligible Bidders are as described in ADB Procurement Guidelines as stated in the Financing Agreement and as described on Asian Development Bank’s web page www.adb.org.</p> <p>An Eligible Bidder shall be deemed to have the nationality of a country if it is a citizen or constituted or incorporated, and operates in conformity with the provisions of the laws of that country.</p>
5.2	<p>Eligible Bidders are as described in ADB Procurement Guidelines as stated in the Financing Agreement and as described on Asian Development Bank’s web page www.adb.org.</p>
5.4	<p>The Bidder must have completed, within the period specified in the Invitation to Bid and ITB Clause 12.1(a)(ii), a single contract that is similar to this Project, equivalent to at least fifty percent (50%) of the ABC.</p> <p>For this purpose, similar contracts shall refer to supply, delivery, installation, commissioning of water supply equipment, instrumentations, etc.</p>
7	<p>Eligible goods and services shall have their origin in eligible source countries as described in ADB Procurement Guidelines as stated in the Financing Agreement and as described on Asian Development Bank’s web page www.adb.org.</p> <p>For the purpose of this Clause, origin means the country where the goods have been grown in, mined, cultivated, produced, manufactured, or processed; or through manufacture, processing, or assembly, another commercially recognized article results that differs substantially in its basic characteristics from its imported components.</p>
8.1	Subcontracting is not allowed.
8.2	Not applicable.
9.1	<p>The Procuring Entity will hold a pre-bid conference for this Project on 18 December 2020 at 02:00p.m. at the:</p> <p style="text-align: center;">Metro Kidapawan Water District</p>

ITB Clause	
	<p>Barangay Lanao, Kidapawan City Cotabato</p> <p>Pre-bid conference may be conducted in person or face-to-face through videoconferencing, webcasting, or similar technology, or a combination thereof.</p>
10.1	<p>The Procuring Entity’s address is:</p> <p style="text-align: center;">Metro Kidapawan Water District Barangay Lanao, Kidapawan City Cotabato</p> <p>Contact person: Ramil A. Condez, CE, RMP, MBA Department Manager A – ECD BAC Chairperson Telephone No. : (064) 577-1533, 577-1865 Email Address: metrokidapawan_wd@yahoo.com</p>
12.1	<p>The first envelope shall contain the following eligibility and technical documents:</p> <p>a. Eligibility Requirements</p> <ol style="list-style-type: none"> i. Registration Certification of the Company (SEC or DTI) OR PhilGEPS Certificate of Platinum Membership; ii. List and copy of relevant contracts that comply to the experience requirement as specified in ITB Clause 5.4; iii. Audited financial statement for the past two years; iv. Committed Line of Credit from a universal or commercial bank, in accordance with ITB Clause 5.5 v. In case of Joint Venture, the JV Agreement, if existing, or a signed Statement from the partner companies that they will enter into a JV in case of award of contract; <p>b. Technical Documents</p> <ol style="list-style-type: none"> vi. Bid Security as required in the ITB 18; vii. Conformity with the technical specifications, as enumerated and specified in Sections VI and VII of the Bidding Documents; viii. Sworn statement in accordance with Section 25.3 of the IRR of RA 9184 and using the form prescribed in Section VIII. Bidding Forms. <p>Foreign bidders may submit the equivalent documents, if any, issued by the country of the foreign bidder.</p>
12.1(a)(ii)	<p>The bidder’s SLCC similar to the contract to be bid per set should have been completed within five (5) years prior to the deadline for the submission and receipt of bids.</p>

ITB Clause																									
13.1	No additional requirements.																								
13.1(b)	Domestic preference is not applicable.																								
13.1(c)	No additional requirements.																								
13.2	Bids that exceed the ABC will not be automatically rejected. Detailed price analysis will be carried out.																								
15.4(a)(iv)	No incidental services are required.																								
15.4(b)	Not applicable. The price of the Goods shall be quoted Delivered Duty Paid (DDP)Kidapawan City, Cotabato. No incidental services are required.																								
16.1(b)	The Bid prices for Goods supplied from outside of the Philippines shall be quoted in Philippine Pesos.																								
16.3	Not applicable.																								
17.1	Bids will be valid until 4May2021																								
18.1	<p>The bid security shall be in the form of any of the following forms and amounts:</p> <p>Set1:</p> <table border="1" data-bbox="408 1249 1385 1406"> <thead> <tr> <th>Form of Bid Security</th> <th>Minimum Amount</th> </tr> </thead> <tbody> <tr> <td>1. Manager's Check (2%)</td> <td>PhP 487,000</td> </tr> <tr> <td>2. Bank draft or Bank Guarantee (2%)</td> <td>PhP 487,000</td> </tr> <tr> <td>3. Surety Bond (5%)</td> <td>PhP 1,217,500.00</td> </tr> </tbody> </table> <p>Set 2:</p> <table border="1" data-bbox="408 1541 1385 1697"> <thead> <tr> <th>Form of Bid Security</th> <th>Minimum Amount</th> </tr> </thead> <tbody> <tr> <td>1. Manager's Check (2%)</td> <td>PhP 412,000.00</td> </tr> <tr> <td>2. Bank draft or Bank Guarantee (2%)</td> <td>PhP 412,000.00</td> </tr> <tr> <td>3. Surety Bond (5%)</td> <td>PhP 1,030,000.00</td> </tr> </tbody> </table> <p>Set 3:</p> <table border="1" data-bbox="408 1832 1385 1989"> <thead> <tr> <th>Form of Bid Security</th> <th>Minimum Amount</th> </tr> </thead> <tbody> <tr> <td>1. Manager's Check (2%)</td> <td>PhP 103,800.00</td> </tr> <tr> <td>2. Bank draft or Bank Guarantee (2%)</td> <td>PhP 103,800.00</td> </tr> <tr> <td>3. Surety Bond (5%)</td> <td>PhP 259,000.00</td> </tr> </tbody> </table>	Form of Bid Security	Minimum Amount	1. Manager's Check (2%)	PhP 487,000	2. Bank draft or Bank Guarantee (2%)	PhP 487,000	3. Surety Bond (5%)	PhP 1,217,500.00	Form of Bid Security	Minimum Amount	1. Manager's Check (2%)	PhP 412,000.00	2. Bank draft or Bank Guarantee (2%)	PhP 412,000.00	3. Surety Bond (5%)	PhP 1,030,000.00	Form of Bid Security	Minimum Amount	1. Manager's Check (2%)	PhP 103,800.00	2. Bank draft or Bank Guarantee (2%)	PhP 103,800.00	3. Surety Bond (5%)	PhP 259,000.00
Form of Bid Security	Minimum Amount																								
1. Manager's Check (2%)	PhP 487,000																								
2. Bank draft or Bank Guarantee (2%)	PhP 487,000																								
3. Surety Bond (5%)	PhP 1,217,500.00																								
Form of Bid Security	Minimum Amount																								
1. Manager's Check (2%)	PhP 412,000.00																								
2. Bank draft or Bank Guarantee (2%)	PhP 412,000.00																								
3. Surety Bond (5%)	PhP 1,030,000.00																								
Form of Bid Security	Minimum Amount																								
1. Manager's Check (2%)	PhP 103,800.00																								
2. Bank draft or Bank Guarantee (2%)	PhP 103,800.00																								
3. Surety Bond (5%)	PhP 259,000.00																								

ITB Clause	
18.2	The bid security shall be valid until 6 June 2021
20.3	Each Bidder shall submit One (1) original and three (3) copies of the first and second components of its bid.
21	<p>The address for submission of bids is:</p> <p style="text-align: center;">Bids and Awards Committee Metro Kidapawan Water District Barangay Lanao, Kidapawan City Cotabato</p> <p>The deadline for submission of bids is 8 January 2021, 02:00 p.m.</p>
24.1	<p>The BAC shall open the bids in public on 8 January 2021, 02:00 p.m. at:</p> <p style="text-align: center;">Metro Kidapawan Water District Barangay Lanao, Kidapawan City Cotabato</p> <p>The time for the bid opening shall be the same as the deadline for receipt of bids or promptly thereafter. Rescheduling the date of the opening of bids shall not be considered except for force majeure, such as natural calamities. In re-scheduling the opening of bids, the BAC shall issue a Notice of Postponement to be posted at the PhilGEPS and the procuring entity's websites.</p>
24.2	During Bid opening, if the first envelope lacks any of the documents listed in the ADB BDS 12.1, the bid shall be declared non-responsive but the documents shall be kept by the Procuring Entity. Only the unopened second envelope shall be returned to the Bidder.
24.3	The BAC shall immediately open the financial proposals in the second envelope of the responsive bids. The bid price shall be read and recorded.
27.1	Domestic preference is not applicable
28.3(a)	<p>Grouping and Evaluation of Sets –</p> <p>Partial bids are allowed. All Goods are grouped in lots listed below. Bidders shall have the option of submitting a proposal on any or all sets and evaluation and contract award will be undertaken on a per lot basis. The sets shall not be divided further into sub-sets for the purpose of bidding, evaluation, and contract award.</p> <p>In all cases, the NFCC computation, if applicable, must be sufficient for all the sets or contracts to be awarded to the Bidder.</p> <p>Set 1-Pumps, Generator Set and Chlorine Gas Feeders</p>

ITB Clause	
	<p>Set 2- Data Loggers and Other Equipment</p> <p>Set 3- CCTV and Monitoring Equipment</p>
28.4	Bids that exceed the ABC per lot will not be automatically rejected. Detailed price analysis will be carried out.
29.2	<p>Certificate of PhilGEPS Platinum Membership, if this has not been submitted in the first envelope of the bid.</p> <p><i>(The latest income and business tax returns are those within the last six months preceding the date of bid submission.)</i></p>
32.4(f)	No additional requirement.

Section IV. General Conditions of Contract

TABLE OF CONTENTS

1.	Definitions.....	4-3
2.	Corrupt, Fraudulent, Collusive, And Coercive Practices.....	4-4
3.	Inspection And Audit By The Funding Source.....	4-5
4.	Governing Law And Language.....	4-5
5.	Notices	4-5
6.	Scope Of Contract.....	4-6
7.	Subcontracting	4-6
8.	Procuring Entity’s Responsibilities.....	4-6
9.	Prices.....	4-6
10.	Payment.....	4-7
11.	Advance Payment And Terms Of Payment	4-7
12.	Taxes And Duties.....	4-8
13.	Performance Security	4-8
14.	Use Of Contract Documents And Information	4-9
15.	Standards.....	4-9
16.	Inspection And Tests.....	4-9
17.	Warranty	4-10
18.	Delays In The Supplier’s Performance	4-11
19.	Liquidated Damages	4-11
20.	Settlement Of Disputes	4-11
21.	Liability Of The Supplier.....	4-12
22.	Force Majeure	4-12
23.	Termination For Default	4-12
24.	Termination For Insolvency.....	4-13
25.	Termination For Convenience	4-13
26.	Termination For Unlawful Acts.....	4-14
27.	Procedures For Termination Of Contracts.....	4-14
28.	Assignment Of Rights.....	4-15
29.	Contract Amendment	4-16
30.	Application.....	4-17

1. Definitions

1.1. In this Contract, the following terms shall be interpreted as indicated:

- (a) “The Contract” means the agreement entered into between the Procuring Entity and the Supplier, as recorded in the Contract Form signed by the parties, including all attachments and appendices thereto and all documents incorporated by reference therein.
- (b) “The Contract Price” means the price payable to the Supplier under the Contract for the full and proper performance of its contractual obligations.
- (c) “The Goods” means all of the supplies, equipment, machinery, spare parts, other materials and/or general support services which the Supplier is required to provide to the Procuring Entity under the Contract.
- (d) “The Services” means those services ancillary to the supply of the Goods, such as transportation and insurance, and any other incidental services, such as installation, commissioning, provision of technical assistance, training, and other such obligations of the Supplier covered under the Contract.
- (e) “GCC” means the General Conditions of Contract contained in this Section.
- (f) “SCC” means the Special Conditions of Contract.
- (g) “The Procuring Entity” means the organization purchasing the Goods, as named in the SCC.
- (h) “The Procuring Entity’s country” is the Philippines.
- (i) “The Supplier” means the individual contractor, manufacturer distributor, or firm supplying/manufacturing the Goods and Services under this Contract and named in the SCC.
- (j) The “Funding Source” means the organization named in the SCC.
- (k) “The Project Site,” where applicable, means the place or places named in the SCC.
- (l) “Day” means calendar day.
- (m) The “Effective Date” of the contract will be the date of signing the contract, however the Supplier shall commence performance of its obligations only upon receipt of the Notice to Proceed and copy of the approved contract.
- (n) “Verified Report” refers to the report submitted by the Implementing Unit to the HoPE setting forth its findings as to the existence of grounds

or causes for termination and explicitly stating its recommendation for the issuance of a Notice to Terminate.

2. Corrupt, Fraudulent, Collusive, and Coercive Practices

2.1. Unless otherwise provided in the SCC, the Procuring Entity as well as the bidders, contractors, or suppliers shall observe the highest standard of ethics during the procurement and execution of this Contract. In pursuance of this policy, the Procuring Entity:

- (a) defines, for the purposes of this provision, the terms set forth below as follows:
 - (i) "corrupt practice" means behavior on the part of officials in the public or private sectors by which they improperly and unlawfully enrich themselves, others, or induce others to do so, by misusing the position in which they are placed, and it includes the offering, giving, receiving, or soliciting of anything of value to influence the action of any such official in the procurement process or in contract execution; entering, on behalf of the Government, into any contract or transaction manifestly and grossly disadvantageous to the same, whether or not the public officer profited or will profit thereby, and similar acts as provided in Republic Act 3019.
 - (ii) "fraudulent practice" means a misrepresentation of facts in order to influence a procurement process or the execution of a contract to the detriment of the Procuring Entity, and includes collusive practices among Bidders (prior to or after bid submission) designed to establish bid prices at artificial, non-competitive levels and to deprive the Procuring Entity of the benefits of free and open competition.
 - (iii) "collusive practices" means a scheme or arrangement between two or more Bidders, with or without the knowledge of the Procuring Entity, designed to establish bid prices at artificial, non-competitive levels.
 - (iv) "coercive practices" means harming or threatening to harm, directly or indirectly, persons, or their property to influence their participation in a procurement process, or affect the execution of a contract;
 - (v) "obstructive practice" is
 - (aa) deliberately destroying, falsifying, altering or concealing of evidence material to an administrative proceedings or investigation or making false statements to investigators in order to materially impede an administrative proceedings or investigation of the Procuring Entity or any foreign government/foreign or

international financing institution into allegations of a corrupt, fraudulent, coercive or collusive practice; and/or threatening, harassing or intimidating any party to prevent it from disclosing its knowledge of matters relevant to the administrative proceedings or investigation or from pursuing such proceedings or investigation; or

(bb) acts intended to materially impede the exercise of the inspection and audit rights of the Procuring Entity or any foreign government/foreign or international financing institution herein.

(b) will reject a proposal for award if it determines that the Bidder recommended for award has engaged in any of the practices mentioned in this Clause for purposes of competing for the contract.

2.2. Further the Funding Source, Borrower or Procuring Entity, as appropriate, will seek to impose the maximum civil, administrative and/or criminal penalties available under the applicable law on individuals and organizations deemed to be involved with any of the practices mentioned in **GCC** Clause 2.1(a).

3. Inspection and Audit by the Funding Source

The Supplier shall permit the Funding Source to inspect the Supplier's accounts and records relating to the performance of the Supplier and to have them audited by auditors appointed by the Funding Source, if so required by the Funding Source.

4. Governing Law and Language

4.1. This Contract shall be interpreted in accordance with the laws of the Republic of the Philippines.

4.2. This Contract has been executed in the English language, which shall be the binding and controlling language for all matters relating to the meaning or interpretation of this Contract. All correspondence and other documents pertaining to this Contract exchanged by the parties shall be written in English.

5. Notices

5.1. Any notice, request, or consent required or permitted to be given or made pursuant to this Contract shall be in writing. Any such notice, request, or consent shall be deemed to have been given or made when received by the concerned party, either in person or through an authorized representative of the Party to whom the communication is addressed, or when sent by registered mail, telex, telegram, or facsimile to such Party at the address specified in the **SCC**, which shall be effective when delivered and duly received or on the notice's effective date, whichever is later.

- 5.2. A Party may change its address for notice hereunder by giving the other Party notice of such change pursuant to the provisions listed in the **SCC** for **GCC** Clause 5.1.

6. Scope of Contract

- 6.1. The Goods and Related Services to be provided shall be as specified in in
- 6.2.
- 6.3.
- 6.4.
- 6.5.
- 6.6.
- 6.7. Section VI. .
- 6.8. This Contract shall include all such items, although not specifically mentioned, that can be reasonably inferred as being required for its completion as if such items were expressly mentioned herein. Any additional requirements for the completion of this Contract shall be provided in the **SCC**.

7. Subcontracting

- 7.1. Subcontracting of any portion of the Goods, if allowed in the **BDS**, does not relieve the Supplier of any liability or obligation under this Contract. The Supplier will be responsible for the acts, defaults, and negligence of any subcontractor, its agents, servants or workmen as fully as if these were the Supplier's own acts, defaults, or negligence, or those of its agents, servants or workmen.
- 7.2. If subcontracting is allowed, the Supplier may identify its subcontractor during contract implementation. Subcontractors disclosed and identified during the bidding may be changed during the implementation of this Contract. In either case, subcontractors must submit the documentary requirements under **ITB** Clause 12 and comply with the eligibility criteria specified in the **BDS**. In the event that any subcontractor is found by the Procuring Entity to be ineligible, the subcontracting of such portion of the Goods shall be disallowed.

8. Procuring Entity's Responsibilities

- 8.1. Whenever the performance of the obligations in this Contract requires that the Supplier obtain permits, approvals, import, and other licenses from local public authorities, the Procuring Entity shall, if so needed by the Supplier, make its best effort to assist the Supplier in complying with such requirements in a timely and expeditious manner.
- 8.2. The Procuring Entity shall pay all costs involved in the performance of its responsibilities in accordance with **GCC** Clause 6.

9. Prices

- 9.1. For the given scope of work in this Contract as awarded, all bid prices are considered fixed prices, and therefore not subject to price escalation during contract implementation, except under extraordinary circumstances and upon prior approval of the GPPB in accordance with Section 61 of R.A. 9184 and its IRR or except as provided in this Clause.
- 9.2. Prices charged by the Supplier for Goods delivered and/or services performed under this Contract shall not vary from the prices quoted by the Supplier in its bid, with the exception of any change in price resulting from a Change Order issued in accordance with **GCC** Clause 29.

10. Payment

- 10.1. Payments shall be made only upon a certification by the HoPE to the effect that the Goods have been rendered or delivered in accordance with the terms of this Contract and have been duly inspected and accepted. Except with the prior approval of the President no payment shall be made for services not yet rendered or for supplies and materials not yet delivered under this Contract. Ten percent (10%) of the amount of each payment shall be retained by the Procuring Entity to cover the Supplier's warranty obligations under this Contract as described in **GCC** Clause 17.
- 10.2. The Supplier's request(s) for payment shall be made to the Procuring Entity in writing, accompanied by an invoice describing, as appropriate, the Goods delivered and/or Services performed, and by documents submitted pursuant to the **SCC** provision for **GCC** Clause 6.8, and upon fulfillment of other obligations stipulated in this Contract.
- 10.3. Pursuant to **GCC** Clause 10.2, payments shall be made promptly by the Procuring Entity, but in no case later than sixty (60) days after submission of an invoice or claim by the Supplier. Payments shall be in accordance with the schedule stated in the **SCC**.
- 10.4. Unless otherwise provided in the **SCC**, the currency in which payment is made to the Supplier under this Contract shall be in Philippine Pesos.
- 10.5. Unless otherwise provided in the **SCC**, payments using Letter of Credit (LC), in accordance with the Guidelines issued by the GPPB, is allowed. For this purpose, the amount of provisional sum is indicated in the **SCC**. All charges for the opening of the LC and/or incidental expenses thereto shall be for the account of the Supplier.

11. Advance Payment and Terms of Payment

- 11.1. Advance payment shall be made only after prior approval of the President, and shall not exceed fifteen percent (15%) of the Contract amount, unless otherwise directed by the President or in cases allowed under Annex "D" of RA 9184.

- 11.2. All progress payments shall first be charged against the advance payment until the latter has been fully exhausted.
- 11.3. For Goods supplied from abroad, unless otherwise indicated in the **SCC**, the terms of payment shall be as follows:
- (a) On Contract Signature: Fifteen Percent (15%) of the Contract Price shall be paid within sixty (60) days from signing of the Contract and upon submission of a claim and a bank guarantee for the equivalent amount valid until the Goods are delivered and in the form provided in Section VIII. Bidding Forms.
 - (b) On Delivery: Sixty-five percent (65%) of the Contract Price shall be paid to the Supplier within sixty (60) days after the date of receipt of the Goods and upon submission of the documents (i) through (vi) specified in the **SCC** provision on Delivery and Documents.
 - (c) On Acceptance: The remaining twenty percent (20%) of the Contract Price shall be paid to the Supplier within sixty (60) days after the date of submission of the acceptance and inspection certificate for the respective delivery issued by the Procuring Entity's authorized representative. In the event that no inspection or acceptance certificate is issued by the Procuring Entity's authorized representative within forty five (45) days of the date shown on the delivery receipt, the Supplier shall have the right to claim payment of the remaining twenty percent (20%) subject to the Procuring Entity's own verification of the reason(s) for the failure to issue documents (vii) and (viii) as described in the **SCC** provision on Delivery and Documents.

12. Taxes and Duties

The Supplier, whether local or foreign, shall be entirely responsible for all the necessary taxes, stamp duties, license fees, and other such levies imposed for the completion of this Contract.

13. Performance Security

- 13.1. Within ten (10) calendar days from receipt of the Notice of Award from the Procuring Entity but in no case later than the signing of the contract by both parties, the successful Bidder shall furnish the performance security in any the forms prescribed in the **ITB** Clause 33.2.
- 13.2. The performance security posted in favor of the Procuring Entity shall be forfeited in the event it is established that the winning bidder is in default in any of its obligations under the contract.
- 13.3. The performance security shall remain valid until issuance by the Procuring Entity of the Certificate of Final Acceptance.
- 13.4. The performance security may be released by the Procuring Entity and returned to the Supplier after the issuance of the Certificate of Final Acceptance subject to the following conditions:

- (a) There are no pending claims against the Supplier or the surety company filed by the Procuring Entity;
- (b) The Supplier has no pending claims for labor and materials filed against it; and
- (c) Other terms specified in the SCC.

13.5. In case of a reduction of the contract value, the Procuring Entity shall allow a proportional reduction in the original performance security, provided that any such reduction is more than ten percent (10%) and that the aggregate of such reductions is not more than fifty percent (50%) of the original performance security.

14. Use of Contract Documents and Information

14.1. The Supplier shall not, except for purposes of performing the obligations in this Contract, without the Procuring Entity's prior written consent, disclose this Contract, or any provision thereof, or any specification, plan, drawing, pattern, sample, or information furnished by or on behalf of the Procuring Entity. Any such disclosure shall be made in confidence and shall extend only as far as may be necessary for purposes of such performance.

14.2. Any document, other than this Contract itself, enumerated in **GCC** Clause 14.1 shall remain the property of the Procuring Entity and shall be returned (all copies) to the Procuring Entity on completion of the Supplier's performance under this Contract if so required by the Procuring Entity.

15. Standards

The Goods provided under this Contract shall conform to the standards mentioned in the

Section VII. Schedule of Requirements

The delivery schedule expressed as weeks/months stipulates hereafter a delivery date which is the date of delivery to the project site - MKWD Service Areas (Kidapawan City, Municipality of Makilala and Municipality of Magpet). Delivery dates of the Goods should not be later than Ninety (90) calendar days upon the receipt of the Notice to Proceed.

Item No	Description	Quantity	Units	Location of Delivery	Delivery Date
Set 1:					
1	Vertical Multistage Centrifugal Booster Pump	6	sets	(1) Brgy. Marbel, Kidapawan City (2) Brgy. Kalaisan, Kidapawan City (3) Brgy. Taluntalunan, Makilala (4) Brgy. San Vicente Makilala (5) Brgy. Magsaysay, Kidapawan City (6) Brgy. Saguing, Makilala	
2	Generator Set 165kVA with Auto-Transfer Switch	6	sets	(1) Brgy. Marbel, Kidapawan City (2) Brgy. Kalaisan, Kidapawan City (3) Brgy. Taluntalunan, Makilala (4) Brgy. San Vicente Makilala (5) Brgy. Magsaysay, Kidapawan City (6) Brgy. Saguing, Makilala	
3	Chlorine Gas Feeder w/ Complete Accessory	6	sets	(1) Brgy. Marbel, Kidapawan City (2) Brgy. Kalaisan, Kidapawan City (3) Brgy. Tagbac, Magpet (4) Brgy. Taluntalunan, Makilala (5) Brgy. San Vicente Makilala (6) Brgy. Balabag, Kidapawan City	

Name of Company in Print

Signature Printed Name of Authorized Representative

Date

Item No	Description	Quantity	Units	Location of Delivery	Delivery Date
Set 2:					
1	Installation Data Logger (Pressure & Flow Reading)	21	units	Refer to Drawings Sheet No. C/15	
2	Installation Data Logger (water level indicator for reservoirs)	21	units	Refer to Drawings Sheet No. C/16	
3	Portable Ultrasonic Flow Meter complete set with	2	units	MKWD Main Office, Brgy. Lanao, Kidapawan City	
4	Portable Water Quality Monitoring Equipment	2	units	MKWD Main Office, Brgy. Lanao, Kidapawan City	
5	Online Water Quality Monitoring Equipment with Data Logger	10	lots	MKWD Main Office, Brgy. Lanao, Kidapawan City	
6	Pumping Station Monitoring System	5	units	Refer to Drawings Sheet No. C/17	
7	Pneumatic Piercing Tool	1	set	MKWD Main Office, Brgy. Lanao, Kidapawan City	
8	Water Meter Calibration Facility Tester Bench Equipment	2	sets	MKWD Manongol Reservoir, Brgy. Manongol, Kidapawan City	
Set 3:					
11	Installation of Central Monitoring Station System Configuration and IT Equipment	1	lot	MKWD Manongol Reservoir, Brgy. Manongol, Kidapawan City	
12	Installation of CCTV Units	12	lots	Refer to Drawings Sheet No. C/18, C/02 to C/14	

Name of Company in Print

Signature Printed Name of Authorized Representative

Date

Section VIII. Technical Specifications; and, when no applicable standard is mentioned, to the authoritative standards appropriate to the Goods' country of origin. Such standards shall be the latest issued by the institution concerned.

16. Inspection and Tests

16.1. The Procuring Entity or its representative shall have the right to inspect and/or to test the Goods to confirm their conformity to the Contract specifications at no extra cost to the Procuring Entity. The **SCC** and

16.2.

16.3.

16.4.

16.5.

16.6.

16.7. Section VII. Schedule of Requirements

The delivery schedule expressed as weeks/months stipulates hereafter a delivery date which is the date of delivery to the project site - MKWD Service Areas (Kidapawan City, Municipality of Makilala and Municipality of Magpet). Delivery dates of the Goods should not be later than Ninety (90) calendar days upon the receipt of the Notice to Proceed.

Item No	Description	Quantity	Units	Location of Delivery	Delivery Date
Set 1:					
1	Vertical Multistage Centrifugal Booster Pump	6	sets	(7) Brgy. Marbel, Kidapawan City (8) Brgy. Kalaisan, Kidapawan City (9) Brgy. Taluntalunan, Makilala (10) Brgy. San Vicente Makilala (11) Brgy. Magsaysay, Kidapawan City (12) Brgy. Saguing, Makilala	
2	Generator Set 165kVA with Auto-Transfer Switch	6	sets	(7) Brgy. Marbel, Kidapawan City (8) Brgy. Kalaisan, Kidapawan City (9) Brgy. Taluntalunan, Makilala (10) Brgy. San Vicente Makilala (11) Brgy. Magsaysay, Kidapawan City (12) Brgy. Saguing, Makilala	
3	Chlorine Gas Feeder w/ Complete Accessory	6	sets	(7) Brgy. Marbel, Kidapawan City (8) Brgy. Kalaisan, Kidapawan City (9) Brgy. Tagbac, Magpet (10) Brgy. Taluntalunan, Makilala (11) Brgy. San Vicente Makilala (12) Brgy. Balabag, Kidapawan City	

Name of Company in Print

Signature Printed Name of Authorized Representative

Date

Item No	Description	Quantity	Units	Location of Delivery	Delivery Date
Set 2:					
1	Installation Data Logger (Pressure & Flow Reading)	21	units	Refer to Drawings Sheet No. C/15	
2	Installation Data Logger (water level indicator for reservoirs)	21	units	Refer to Drawings Sheet No. C/16	
3	Portable Ultrasonic Flow Meter complete set with	2	units	MKWD Main Office, Brgy. Lanao, Kidapawan City	
4	Portable Water Quality Monitoring Equipment	2	units	MKWD Main Office, Brgy. Lanao, Kidapawan City	
5	Online Water Quality Monitoring Equipment with Data Logger	10	lots	MKWD Main Office, Brgy. Lanao, Kidapawan City	
6	Pumping Station Monitoring System	5	units	Refer to Drawings Sheet No. C/17	
7	Pneumatic Piercing Tool	1	set	MKWD Main Office, Brgy. Lanao, Kidapawan City	
8	Water Meter Calibration Facility Tester Bench Equipment	2	sets	MKWD Manongol Reservoir, Brgy. Manongol, Kidapawan City	
Set 3:					
11	Installation of Central Monitoring Station System Configuration and IT Equipment	1	lot	MKWD Manongol Reservoir, Brgy. Manongol, Kidapawan City	
12	Installation of CCTV Units	12	lots	Refer to Drawings Sheet No. C/18, C/02 to C/14	

Name of Company in Print

Signature Printed Name of Authorized Representative

Date

- 16.8. Section VIII. Technical Specifications shall specify what inspections and/or tests the Procuring Entity requires and where they are to be conducted. The Procuring Entity shall notify the Supplier in writing, in a timely manner, of the identity of any representatives retained for these purposes.
- 16.9. If applicable, the inspections and tests may be conducted on the premises of the Supplier or its subcontractor(s), at point of delivery, and/or at the goods' final destination. If conducted on the premises of the Supplier or its subcontractor(s), all reasonable facilities and assistance, including access to drawings and production data, shall be furnished to the inspectors at no charge to the Procuring Entity. The Supplier shall provide the Procuring Entity with results of such inspections and tests.
- 16.10. The Procuring Entity or its designated representative shall be entitled to attend the tests and/or inspections referred to in this Clause provided that the Procuring Entity shall bear all of its own costs and expenses incurred in connection with such attendance including, but not limited to, all traveling and board and lodging expenses.
- 16.11. The Procuring Entity may reject any Goods or any part thereof that fail to pass any test and/or inspection or do not conform to the specifications. The Supplier shall either rectify or replace such rejected Goods or parts thereof or make alterations necessary to meet the specifications at no cost to the Procuring Entity, and shall repeat the test and/or inspection, at no cost to the Procuring Entity, upon giving a notice pursuant to GCC Clause 5.
- 16.12. The Supplier agrees that neither the execution of a test and/or inspection of the Goods or any part thereof, nor the attendance by the Procuring Entity or its representative, shall release the Supplier from any warranties or other obligations under this Contract.

17. Warranty

- 17.1. The Supplier warrants that the Goods supplied under the Contract are new, unused, of the most recent or current models, and that they incorporate all recent improvements in design and materials, except when the technical specifications required by the Procuring Entity provides otherwise.
- 17.2. The Supplier further warrants that all Goods supplied under this Contract shall have no defect, arising from design, materials, or workmanship or from any

act or omission of the Supplier that may develop under normal use of the supplied Goods in the conditions prevailing in the country of final destination.

- 17.3. In order to assure that manufacturing defects shall be corrected by the Supplier, a warranty shall be required from the Supplier for a minimum period specified in the **SCC**. The obligation for the warranty shall be covered by, at the Supplier's option, either retention money in an amount equivalent to at least one percent (1%) of every progress payment, or a special bank guarantee equivalent to at least one percent (1%) of the total Contract Price or other such amount if so specified in the **SCC**. The said amounts shall only be released after the lapse of the warranty period specified in the **SCC**; provided, however, that the Supplies delivered are free from patent and latent defects and all the conditions imposed under this Contract have been fully met.
- 17.4. The Procuring Entity shall promptly notify the Supplier in writing of any claims arising under this warranty. Upon receipt of such notice, the Supplier shall, within the period specified in the **SCC** and with all reasonable speed, repair or replace the defective Goods or parts thereof, without cost to the Procuring Entity.
- 17.5. If the Supplier, having been notified, fails to remedy the defect(s) within the period specified in **GCC** Clause 17.4, the Procuring Entity may proceed to take such remedial action as may be necessary, at the Supplier's risk and expense and without prejudice to any other rights which the Procuring Entity may have against the Supplier under the Contract and under the applicable law.

18. Delays in the Supplier's Performance

- 18.1. Delivery of the Goods and/or performance of Services shall be made by the Supplier in accordance with the time schedule prescribed by the Procuring Entity in
- 18.2.
- 18.3.
- 18.4.
- 18.5.
- 18.6.
- 18.7. Section VI. .
- 18.8. If at any time during the performance of this Contract, the Supplier or its Subcontractor(s) should encounter conditions impeding timely delivery of the Goods and/or performance of Services, the Supplier shall promptly notify the

Procuring Entity in writing of the fact of the delay, its likely duration and its cause(s). As soon as practicable after receipt of the Supplier's notice, and upon causes provided for under **GCC Clause 22**, the Procuring Entity shall evaluate the situation and may extend the Supplier's time for performance, in which case the extension shall be ratified by the parties by amendment of Contract.

- 18.9. Except as provided under **GCC Clause 22**, a delay by the Supplier in the performance of its obligations shall render the Supplier liable to the imposition of liquidated damages pursuant to **GCC Clause 19**, unless an extension of time is agreed upon pursuant to **GCC Clause 29** without the application of liquidated damages.

19. Liquidated Damages

Subject to **GCC Clauses 18 and 22**, if the Supplier fails to satisfactorily deliver any or all of the Goods and/or to perform the Services within the period(s) specified in this Contract inclusive of duly granted time extensions if any, the Procuring Entity shall, without prejudice to its other remedies under this Contract and under the applicable law, deduct from the Contract Price, as liquidated damages, the applicable rate of one tenth (1/10) of one (1) percent of the cost of the unperformed portion for every day of delay until actual delivery or performance. The maximum deduction shall be ten percent (10%) of the amount of contract. Once the maximum is reached, the Procuring Entity may rescind or terminate the Contract pursuant to **GCC Clause 23**, without prejudice to other courses of action and remedies open to it.

20. Settlement of Disputes

- 20.1. If any dispute or difference of any kind whatsoever shall arise between the Procuring Entity and the Supplier in connection with or arising out of this Contract, the parties shall make every effort to resolve amicably such dispute or difference by mutual consultation.
- 20.2. If after thirty (30) days, the parties have failed to resolve their dispute or difference by such mutual consultation, then either the Procuring Entity or the Supplier may give notice to the other party of its intention to commence arbitration, as hereinafter provided, as to the matter in dispute, and no arbitration in respect of this matter may be commenced unless such notice is given.
- 20.3. Any dispute or difference in respect of which a notice of intention to commence arbitration has been given in accordance with this Clause shall be settled by arbitration. Arbitration may be commenced prior to or after delivery of the Goods under this Contract.
- 20.4. In the case of a dispute between the Procuring Entity and the Supplier, the dispute shall be resolved in accordance with Republic Act 9285 ("R.A. 9285"), otherwise known as the "Alternative Dispute Resolution Act of 2004."
- 20.5. Notwithstanding any reference to arbitration herein, the parties shall continue to perform their respective obligations under the Contract unless they

otherwise agree; and the Procuring Entity shall pay the Supplier any monies due the Supplier.

21. Liability of the Supplier

- 21.1. The Supplier’s liability under this Contract shall be as provided by the laws of the Republic of the Philippines, subject to additional provisions, if any, set forth in the **SCC**.
- 21.2. Except in cases of criminal negligence or willful misconduct, and in the case of infringement of patent rights, if applicable, the aggregate liability of the Supplier to the Procuring Entity shall not exceed the total Contract Price, provided that this limitation shall not apply to the cost of repairing or replacing defective equipment.

22. Force Majeure

- 22.1. The Supplier shall not be liable for forfeiture of its performance security, liquidated damages, or termination for default if and to the extent that the Supplier’s delay in performance or other failure to perform its obligations under the Contract is the result of a *force majeure*.
- 22.2. For purposes of this Contract the terms “*force majeure*” and “fortuitous event” may be used interchangeably. In this regard, a fortuitous event or *force majeure* shall be interpreted to mean an event which the Supplier could not have foreseen, or which though foreseen, was inevitable. It shall not include ordinary unfavorable weather conditions; and any other cause the effects of which could have been avoided with the exercise of reasonable diligence by the Supplier. Such events may include, but not limited to, acts of the Procuring Entity in its sovereign capacity, wars or revolutions, fires, floods, epidemics, quarantine restrictions, and freight embargoes.
- 22.3. If a *force majeure* situation arises, the Supplier shall promptly notify the Procuring Entity in writing of such condition and the cause thereof. Unless otherwise directed by the Procuring Entity in writing, the Supplier shall continue to perform its obligations under the Contract as far as is reasonably practical, and shall seek all reasonable alternative means for performance not prevented by the *force majeure*.

23. Termination for Default

- 23.1. The Procuring Entity shall terminate this Contract for default when any of the following conditions attends its implementation:
- (a) Outside of *force majeure*, the Supplier fails to deliver or perform any or all of the Goods within the period(s) specified in the contract, or within any extension thereof granted by the Procuring Entity pursuant to a request made by the Supplier prior to the delay, and such failure amounts to at least ten percent (10%) of the contract price;

- (b) As a result of *force majeure*, the Supplier is unable to deliver or perform any or all of the Goods, amounting to at least ten percent (10%) of the contract price, for a period of not less than sixty (60) calendar days after receipt of the notice from the Procuring Entity stating that the circumstance of force majeure is deemed to have ceased; or
 - (c) The Supplier fails to perform any other obligation under the Contract.
- 23.2. In the event the Procuring Entity terminates this Contract in whole or in part, for any of the reasons provided under GCC Clauses 23 to 26, the Procuring Entity may procure, upon such terms and in such manner as it deems appropriate, Goods or Services similar to those undelivered, and the Supplier shall be liable to the Procuring Entity for any excess costs for such similar Goods or Services. However, the Supplier shall continue performance of this Contract to the extent not terminated.
- 23.3. In case the delay in the delivery of the Goods and/or performance of the Services exceeds a time duration equivalent to ten percent (10%) of the specified contract time plus any time extension duly granted to the Supplier, the Procuring Entity may terminate this Contract, forfeit the Supplier's performance security and award the same to a qualified Supplier.

24. Termination for Insolvency

The Procuring Entity shall terminate this Contract if the Supplier is declared bankrupt or insolvent as determined with finality by a court of competent jurisdiction. In this event, termination will be without compensation to the Supplier, provided that such termination will not prejudice or affect any right of action or remedy which has accrued or will accrue thereafter to the Procuring Entity and/or the Supplier.

25. Termination for Convenience

- 25.1. The Procuring Entity may terminate this Contract, in whole or in part, at any time for its convenience. The HoPE may terminate a contract for the convenience of the Government if he has determined the existence of conditions that make Project Implementation economically, financially or technically impractical and/or unnecessary, such as, but not limited to, fortuitous event(s) or changes in law and national government policies.
- 25.2. The Goods that have been delivered and/or performed or are ready for delivery or performance within thirty (30) calendar days after the Supplier's receipt of Notice to Terminate shall be accepted by the Procuring Entity at the contract terms and prices. For Goods not yet performed and/or ready for delivery, the Procuring Entity may elect:
- (a) to have any portion delivered and/or performed and paid at the contract terms and prices; and/or

- (b) to cancel the remainder and pay to the Supplier an agreed amount for partially completed and/or performed goods and for materials and parts previously procured by the Supplier.

25.3. If the Supplier suffers loss in its initial performance of the terminated contract, such as purchase of raw materials for goods specially manufactured for the Procuring Entity which cannot be sold in open market, it shall be allowed to recover partially from this Contract, on a *quantum meruit* basis. Before recovery may be made, the fact of loss must be established under oath by the Supplier to the satisfaction of the Procuring Entity before recovery may be made.

26. Termination for Unlawful Acts

26.1. The Procuring Entity may terminate this Contract in case it is determined *prima facie* that the Supplier has engaged, before or during the implementation of this Contract, in unlawful deeds and behaviors relative to contract acquisition and implementation. Unlawful acts include, but are not limited to, the following:

- (a) Corrupt, fraudulent, and coercive practices as defined in **ITB** Clause 3.1(a);
- (b) Drawing up or using forged documents;
- (c) Using adulterated materials, means or methods, or engaging in production contrary to rules of science or the trade; and
- (d) Any other act analogous to the foregoing.

27. Procedures for Termination of Contracts

27.1. The following provisions shall govern the procedures for termination of this Contract:

- (a) Upon receipt of a written report of acts or causes which may constitute ground(s) for termination as aforementioned, or upon its own initiative, the Implementing Unit shall, within a period of seven (7) calendar days, verify the existence of such ground(s) and cause the execution of a Verified Report, with all relevant evidence attached;
- (b) Upon recommendation by the Implementing Unit, the HoPE shall terminate this Contract only by a written notice to the Supplier conveying the termination of this Contract. The notice shall state:
 - (i) that this Contract is being terminated for any of the ground(s) afore-mentioned, and a statement of the acts that constitute the ground(s) constituting the same;
 - (ii) the extent of termination, whether in whole or in part;

- (iii) an instruction to the Supplier to show cause as to why this Contract should not be terminated; and
 - (iv) special instructions of the Procuring Entity, if any.
- (c) The Notice to Terminate shall be accompanied by a copy of the Verified Report;
- (d) Within a period of seven (7) calendar days from receipt of the Notice of Termination, the Supplier shall submit to the HoPEa verified position paper stating why this Contract should not be terminated. If the Supplier fails to show cause after the lapse of the seven (7) day period, either by inaction or by default, the HoPE shall issue an order terminating this Contract;
- (e) The Procuring Entity may, at any time before receipt of the Supplier's verified position paper described in item (d) above withdraw the Notice to Terminate if it is determined that certain items or works subject of the notice had been completed, delivered, or performed before the Supplier's receipt of the notice;
- (f) Within a non-extendible period of ten (10) calendar days from receipt of the verified position paper, the HoPE shall decide whether or not to terminate this Contract. It shall serve a written notice to the Supplier of its decision and, unless otherwise provided, this Contract is deemed terminated from receipt of the Supplier of the notice of decision. The termination shall only be based on the ground(s) stated in the Notice to Terminate;
- (g) The HoPE may create a Contract Termination Review Committee (CTRC) to assist him in the discharge of this function. All decisions recommended by the CTRC shall be subject to the approval of the HoPE; and
- (h) The Supplier must serve a written notice to the Procuring Entity of its intention to terminate the contract at least thirty (30) calendar days before its intended termination. The Contract is deemed terminated if it is not resumed in thirty (30) calendar days after the receipt of such notice by the Procuring Entity.

28. Assignment of Rights

The Supplier shall not assign his rights or obligations under this Contract, in whole or in part, except with the Procuring Entity's prior written consent.

29. Contract Amendment

Subject to applicable laws, no variation in or modification of the terms of this Contract shall be made except by written amendment signed by the parties.

30. Application

These General Conditions shall apply to the extent that they are not superseded by provisions of other parts of this Contract.

Section V. Special Conditions of Contract

Special Conditions of Contract

GCC Clause	
1.1(g)	<p>The description or list of “Goods” which the Bidder/Supplier is required to provide to the Procuring Entity under the Contract:</p> <p>Set 1:</p> <ol style="list-style-type: none"> 1. Centrifugal Booster Pump- 6 sets 2. Generator Set, 165kVA with ATS- 6 sets 3. Chlorine Gas Feeder w/ Complete Accessory-6 sets <p>Set 2:</p> <ol style="list-style-type: none"> 1. Data Loggers- 21 units (Pressure and Flow Reading); 2. Data Loggers- 21 units (Water Level Indicator for Reservoirs) 3. Portable Ultrasonic Flow Meter-2 units 4. Portable Water Quality Monitoring Equipment-2 units 5. Online Water Quality Monitoring Equipment w/ Data Logger-10 lots 6. Pumping Station Monitoring System-5 units 7. Pneumatic Piercing Tool-1 set 8. Water Meter Calibration Facility Tester Bench Equipment-2 sets <p>Set 3:</p> <ol style="list-style-type: none"> 1. Installation of Central Monitoring Station System Configuration and IT Equipment-1 lot 2. Installation of CCTV Units-12 lots
1.1(g)	<p>The description or list of “Services” which are ancillary to the supply of Goods and all obligations of the Bidder/Supplier covered under the Contract (construction- Main Central Monitoring System, installation, commissioning of equipment, provision of technical assistance, training).</p>
1.1(g)	<p>The Procuring Entity is Metro Kidapawan Water District.</p>
1.1(i)	<p>The Supplier is: <i>[to be inserted at the time of contract award]</i>.</p>
1.1(j)	<p>The Funding Source is the Asian Development Bank (ADB) through Loan No. 3389-PHI.</p>
1.1(k)	<p>The Project Site is: Refer to Section VI. Drawings</p>
2.1	<p>ADB’s Anticorruption Policy requires Borrowers (including beneficiaries of ADB-financed activity), as well as Bidders, Suppliers, and Contractors under ADB-financed contracts, observe the highest standard of ethics during the procurement and execution of such contracts. In pursuance of this policy, ADB</p>

GCC Clause	
	<p>(a) defines, for the purposes of this provision, the terms set forth below as follows:</p> <p>(i) “corrupt practice” means the offering, giving, receiving, or soliciting, directly or indirectly, anything of value to influence improperly the actions of another party;</p> <p>(ii) “fraudulent practice” means any act or omission, including a misrepresentation, that knowingly or recklessly misleads, or attempts to mislead, a party to obtain a financial or other benefit or to avoid an obligation;</p> <p>(iii) “coercive practice” means impairing or harming, or threatening to impair or harm, directly or indirectly, any party or the property of the party to influence improperly the actions of a party;</p> <p>(iv) “collusive practice” means an arrangement between two or more parties designed to achieve an improper purpose, including influencing improperly the actions of another party;</p> <p>(v) “abuse” means theft, waste or improper use of assets related to ADB-related activity, either committed intentionally or through reckless disregard;</p> <p>(vi) “conflict of interest” means any situation in which a party has interests that could improperly influence that party’s performance of official duties or responsibilities, contractual obligations, or compliance with applicable laws and regulations;</p> <p>(vii) “obstructive practice” means (a) deliberately destroying, falsifying, altering or concealing of evidence material to an ADB investigation, or deliberately making false statements to investigators, with the intent to impede an ADB investigation; (b) threatening, harassing or intimidating any party to prevent it from disclosing its knowledge of matters relevant to a Bank investigation or from pursuing the investigation; or (c) deliberate acts intended to impede the exercise of ADB’s contractual rights of audit or inspection or access to information; and</p> <p>(viii) “integrity violation” is any act, as defined under ADB’s Integrity Principles and Guidelines, which violates ADB’s Anticorruption Policy, including (i) to (vii) above and the following: abuse, conflict of interest, violations of ADB sanctions, retaliation against whistleblowers or witnesses, and other violations of ADB’s Anticorruption Policy, including failure to adhere to the highest ethical standard.</p>

GCC Clause	
	<p>(b) will reject a proposal for award if it determines that the Bidder recommended for award has, directly or through an agent, engaged in corrupt, fraudulent, collusive, coercive, or obstructive practices or other integrity violations in competing for the Contract;</p> <p>(c) will cancel the portion of the financing allocated to a contract if it determines at any time that representatives of the borrower or of a beneficiary of ADB-financing engaged in corrupt, fraudulent, collusive, coercive, or obstructive practices or other integrity violations during the procurement or the execution of that contract, without the borrower having taken timely and appropriate action satisfactory to ADB to remedy the situation; and</p> <p>(d) will impose remedial actions on a firm or an individual, at any time, in accordance with ADB’s Anticorruption Policy and Integrity Principles and Guidelines (both as amended from time to time), including declaring ineligible, either indefinitely or for a stated period of time, to participate in ADB-financed, -administered, or -supported activities or to benefit from an ADB-financed, -administered, or -supported contract, financially or otherwise, if it at any time determines that the firm or individual has, directly or through an agent, engaged in corrupt, fraudulent, collusive, coercive, or obstructive practices or other integrity violations.</p> <p>All Bidders, consultants, contractors, suppliers and other third parties engaged or involved in ADB-related activities have a duty to cooperate fully in any screening or investigation when requested by ADB to do so. Such cooperation includes, but is not limited to, the following:</p> <p>(a) being available to be interviewed and replying fully and truthfully to all questions asked;</p> <p>(b) providing ADB with any items requested that are within the party’s control including, but not limited to, documents and other physical objects;</p> <p>© upon written request by ADB, authorizing other related entities to release directly to ADB such information that is specifically and materially related, directly or indirectly, to the said entities or issues which are the subject of the investigation;</p> <p>(d) cooperating with all reasonable requests to search or physically inspect their person and/or work areas, including files, electronic databases, and personal property used on ADB activities, or that utilizes ADB’s ICT resources or systems (including mobile phones, personal electronic devices, and electronic storage devices such as external disk drives);</p>

GCC Clause	
	<p>© cooperating in any testing requested by ADB, including but not limited to, fingerprint identification, handwriting analysis, and physical examination and analysis; and</p> <p>(f) preserving and protecting confidentiality of all information discussed with, and as required by, ADB.</p> <p>All Bidders, consultants, contractors and suppliers shall ensure that, in its contract with its sub-consultants, sub-contractors and other third parties engaged or involved in ADB-related activities, such sub-consultants, sub-contractors and other third parties similarly undertake the foregoing duty to cooperate fully in any screening or investigation when requested by ADB to do so.</p> <p>The Supplier shall permit ADB to inspect the Supplier’s accounts and records relating to the performance of the Supplier and to have them audited by auditors appointed by ADB, if so required by ADB.</p>
5.1	<p>The Procuring Entity’s address for Notices is:</p> <p style="text-align: center;">Metro Kidapawan Water District Barangay Lanao, Kidapawan City Cotabato</p> <p>Contact person: Ramil A. Condez, CE, RMP, MBA Department Manager A – ECD BAC Chairperson Telephone No.: (064) 577-1533, 577-1865 Email Address: <u>metrokidapawan_wd@yahoo.com</u></p> <p>The Supplier’s address for Notices is:</p> <p>Address: _____ Contact Person: _____ Fax and telephone nos.: _____</p>
6.8	<p>Delivery and Documents –</p> <p>For purposes of the Contract, “EXW,” “FOB,” “FCA,” “CIF,” “CIP,” “DDP” and other trade terms used to describe the obligations of the parties shall have the meanings assigned to them by the current edition of INCOTERMS published by the International Chamber of Commerce, Paris. The Delivery terms of this Contract shall be as follows:</p> <p>For Goods Supplied from Abroad: The delivery terms applicable to the Contract are DDP delivered Manongol Reservoir, Barangay Manongol, Kidapawan City, Cotabato</p>

GCC Clause	
	<p>in accordance with INCOTERMS 2020.</p> <p>For Goods Supplied from Within the Philippines: The delivery terms applicable to this Contract are delivered Metro Kidapawan, Negros Oriental. Risk and title will pass from the Supplier to the Procuring Entity upon receipt and final acceptance of the Goods at their final destination.</p> <p>Delivery of the Goods shall be made by the Supplier in accordance with the terms specified in</p> <p>Section VI. . The details of shipping and/or other documents to be furnished by the Supplier are as follows:</p> <p>For Goods supplied from within the Philippines: Upon delivery of the Goods to the Project Site, the Supplier shall notify the Procuring Entity and present the following documents to the Procuring Entity:</p> <ul style="list-style-type: none"> (i) Original and four copies of the Supplier’s invoice showing Goods’ description, quantity, unit price, and total amount; (ii) Original and four copies delivery receipt/note, railway receipt, or truck receipt; (iii) Original Supplier’s factory inspection report; (iv) Original and four copies of the Manufacturer’s and/or Supplier’s warranty certificate; (v) Original and four copies of the certificate of origin (for imported Goods); (vi) Delivery receipt detailing number and description of items received signed by the authorized receiving personnel; (vii) Certificate of Acceptance/Inspection Report signed by the Procuring Entity’s representative at the Project Site; and (viii) Four copies of the Invoice Receipt for Property signed by the Procuring Entity’s representative at the Project Site.

GCC Clause	
	<p>For Goods supplied from abroad: Upon shipment, the Supplier shall notify the Procuring Entity and the insurance company by cable the full details of the shipment, including Contract Number, description of the Goods, quantity, vessel, bill of lading number and date, port of loading, date of shipment, port of discharge etc. Upon delivery to the Project Site, the Supplier shall notify the Procuring Entity and present the following documents as applicable with the documentary requirements of any letter of credit issued taking precedence:</p> <ul style="list-style-type: none"> (i) Original and four copies of the Supplier’s invoice showing Goods’ description, quantity, unit price, and total amount; (ii) Original and four copies of the negotiable, clean shipped on board bill of lading marked “freight pre-paid” and five copies of the non-negotiable bill of lading; (iii) Original Supplier’s factory inspection report; (iv) Original and four copies of the Manufacturer’s and/or Supplier’s warranty certificate; (v) Original and four copies of the certificate of origin (for imported Goods); (vi) Delivery receipt detailing number and description of items received signed by the Procuring Entity’s representative at the Project Site; (vii) Certificate of Acceptance/Inspection Report signed by the Procuring Entity’s representative at the Project Site; and (viii) Four copies of the Invoice Receipt for Property signed by the Procuring Entity’s representative at the Project Site. <p>For purposes of this Clause the Procuring Entity’s Representative at the Project Site is: _____</p> <p>Incidental Services –</p> <p>The Supplier is required to provide all of the following services, including additional services, if any, specified in</p>

GCC Clause	
	<p>Section VI. :</p> <ul style="list-style-type: none"> (a) furnishing of a detailed operations and maintenance manual for each appropriate unit of the supplied Goods; (b) maintenance and/or repair of the supplied Goods, for a period of time agreed by the parties, provided that this service shall not relieve the Supplier of any warranty obligations under this Contract; and (c) training of the Procuring Entity’s personnel, at the Supplier’s plant and/or on-site, in assembly, start-up, operation, maintenance, and/or repair of the supplied Goods. <p>The Contract price for the Goods shall include the prices charged by the Supplier for incidental services and shall not exceed the prevailing rates charged to other parties by the Supplier for similar services.</p> <p>Spare Parts –</p> <p>The Supplier is required to provide all of the following materials, notifications, and information pertaining to spare parts manufactured or distributed by the Supplier:</p> <ul style="list-style-type: none"> (a) such spare parts as the Procuring Entity may elect to purchase from the Supplier, provided that this election shall not relieve the Supplier of any warranty obligations under this Contract; and (b) in the event of termination of production of the spare parts: <ul style="list-style-type: none"> i. advance notification to the Procuring Entity of the pending termination, in sufficient time to permit the Procuring Entity to procure needed requirements; and ii. following such termination, furnishing at no cost to the Procuring Entity, the blueprints, drawings, and specifications of the spare parts, if requested. <p>The spare parts required are listed in</p>

GCC Clause	
	<p>Section VI. and the cost thereof are included in the Contract Price</p> <p>The Supplier shall carry sufficient inventories to assure ex-stock supply of consumable spares for the Goods for a period of five (5) years.</p> <p>Other spare parts and components shall be supplied as promptly as possible, but in any case within one (1) month of placing the order.</p> <p>Packaging –</p> <p>The Supplier shall provide such packaging of the Goods as is required to prevent their damage or deterioration during transit to their final destination, as indicated in this Contract. The packaging shall be sufficient to withstand, without limitation, rough handling during transit and exposure to extreme temperatures, salt and precipitation during transit, and open storage. Packaging case size and weights shall take into consideration, where appropriate, the remoteness of the GOODS’ final destination and the absence of heavy handling facilities at all points in transit.</p> <p>The packaging, marking, and documentation within and outside the packages shall comply strictly with such special requirements as shall be expressly provided for in the Contract, including additional requirements, if any, specified below, and in any subsequent instructions ordered by the Procuring Entity.</p> <p>The outer packaging must be clearly marked on at least four (4) sides as follows:</p> <p>Name of the Procuring Entity</p> <p>Name of the Supplier</p> <p>Contract Description</p> <p>Final Destination</p> <p>Gross weight</p> <p>Any special lifting instructions</p> <p>Any special handling instructions</p> <p>Any relevant HAZCHEM classifications</p> <p>A packaging list identifying the contents and quantities of the package</p>

GCC Clause	
	<p>is to be placed on an accessible point of the outer packaging if practical. If not practical the packaging list is to be placed inside the outer packaging but outside the secondary packaging.</p> <p>Insurance –</p> <p>The Goods supplied under this Contract shall be fully insured by the Supplier in a freely convertible currency against loss or damage incidental to manufacture or acquisition, transportation, storage, and delivery. The Goods remain at the risk and title of the Supplier until their final acceptance by the Procuring Entity.</p> <p>Transportation –</p> <p>Where the Supplier is required under Contract to deliver the Goods CIF, CIP or DDP, transport of the Goods to the port of destination or such other named place of destination in the Philippines, as shall be specified in this Contract, shall be arranged and paid for by the Supplier, and the cost thereof shall be included in the Contract Price.</p> <p>Where the Supplier is required under this Contract to transport the Goods to a specified place of destination within the Philippines, defined as the Project Site, transport to such place of destination in the Philippines, including insurance and storage, as shall be specified in this Contract, shall be arranged by the Supplier, and related costs shall be included in the Contract Price.</p> <p>Where the Supplier is required under Contract to deliver the Goods CIF, CIP or DDP, Goods are to be transported on carriers of Philippine registry. In the event that no carrier of Philippine registry is available, Goods may be shipped by a carrier which is not of Philippine registry provided that the Supplier obtains and presents to the Procuring Entity certification to this effect from the nearest Philippine consulate to the port of dispatch. In the event that carriers of Philippine registry are available but their schedule delays the Supplier in its performance of this Contract the period from when the Goods were first ready for shipment and the actual date of shipment the period of delay will be considered <i>force majeure</i> in accordance with GCC Clause 22.</p> <p>The Procuring Entity accepts no liability for the damage of Goods during transit other than those prescribed by INCOTERMS for DDP Deliveries. In the case of Goods supplied from within the Philippines or supplied by domestic Suppliers risk and title will not be deemed to have passed to the Procuring Entity until their receipt and final acceptance at the final destination.</p> <p>Patent Rights –</p>

GCC Clause	
	The Supplier shall indemnify the Procuring Entity against all third-party claims of infringement of patent, trademark, or industrial design rights arising from use of the Goods or any part thereof.
10.4	Not applicable.
11.3	Maintain the GCC Clause.
13.4(c)	No further instructions.
17.3	One-year warranty for the Goods. Warranty service and after-market support for the Goods shall be available through authorized manufacturer in the Philippines.
17.4	The period for correction of defects in the warranty period is seven (7) days.
21.1	If the Supplier is a joint venture, “All partners to the joint venture shall be jointly and severally liable to the Procuring Entity.”
31	<p>Add the following as SCC Clause 31</p> <p>“31. Respectful Work Environment</p> <p>31.1 The Supplier shall ensure that its employees and Subcontractors observe the highest ethical standards and refrain from any form of bullying, discrimination, misconduct and harassment, including sexual harassment and shall, at all times, behave in a manner that creates an environment free of unethical behavior, bullying, misconduct and harassment, including sexual harassment. The Supplier shall take appropriate action against any employees or Subcontractors, including suspension or termination of employment or subcontract, if any form of unethical or inappropriate behavior is identified.</p> <p>31.2. The Supplier shall conduct training programs for its employees and Subcontractors to raise awareness on and prevent any form of bullying, discrimination, misconduct, and harassment including sexual harassment, and to promote a respectful work environment. The Supplier shall keep an up to date record of its employees and subcontractors who have attended and completed such training programs and provide such records to the Purchaser at their first written request.”</p>

Section VI. Drawings

TABLE OF CONTENTS

Item No.	Title	Sheet No.
1	Taluntalunan Pumps and Genset and Water Impounding Structure	C/20
2	Marbel Pumps and Genset and Water Impounding Structure	C/21
3	San Vicente Pumps and Genset and Water Impounding Structure	C/24
4	Magsaysay Pumps and Genset	C/23
5	Saguing Pumps and Genset	C/25
6	Marbel Water Impounding Structure	A/29
7	Magpet Water Impounding Structure	A/45
8	Kalaisan Water Impounding Structure	A/62
9	Taluntalunan Water Impounding Structure	A/70
10	San Vicente Water Impounding Structure	A/79
11	Data Loggers for Existing Flow Meters	C/15
12	Installation of Data Loggers for Reservoirs	C/16
13	Pumping Facility Monitoring Equipment	C/17
14	Installation of CCTV System	C/18
15	Proposed CCTV Camera, Amas Reservoir	C/02
16	Proposed CCTV Camera, Matalam Reservoir	C/03
17	Proposed CCTV Camera, Saguing Reservoir	C/04
18	Proposed CCTV Camera, Cotelco Village Reservoir	C/05
19	Proposed CCTV Camera, Muaan Reservoir	C/06
20	Proposed CCTV Camera, Makilala Reservoir 2, Saguing	C/07
21	Proposed CCTV Camera, Magsaysay Reservoir	C/08
22	Proposed CCTV Camera, Makilala Reservoir	C/09
23	Proposed CCTV Camera, Lapaan Treatment Plant Facilities	C/11
24	Proposed CCTV Camera, Pinag Inaman Spring Source	C/12

Item No.	Title	Sheet No.
25	Proposed CCTV Camera, Manongol Reservoir Complex	C/13
26	Proposed Motorpool	C/14

Section VII. Schedule of Requirements

The delivery schedule expressed as weeks/months stipulates hereafter a delivery date which is the date of delivery to the project site - MKWD Service Areas (Kidapawan City, Municipality of Makilala and Municipality of Magpet). Delivery dates of the Goods should not be later than Ninety (90) calendar days upon the receipt of the Notice to Proceed.

Item No	Description	Quantity	Units	Location of Delivery	Delivery Date
Set 1:					
1	Vertical Multistage Centrifugal Booster Pump	6	sets	(13) Brgy. Marbel, Kidapawan City (14) Brgy. Kalaisan, Kidapawan City (15) Brgy. Taluntalunan, Makilala (16) Brgy. San Vicente Makilala (17) Brgy. Magsaysay, Kidapawan City (18) Brgy. Saguing, Makilala	
2	Generator Set 165kVA with Auto-Transfer Switch	6	sets	(13) Brgy. Marbel, Kidapawan City (14) Brgy. Kalaisan, Kidapawan City (15) Brgy. Taluntalunan, Makilala (16) Brgy. San Vicente Makilala (17) Brgy. Magsaysay, Kidapawan City (18) Brgy. Saguing, Makilala	
3	Chlorine Gas Feeder w/ Complete Accessory	6	sets	(13) Brgy. Marbel, Kidapawan City (14) Brgy. Kalaisan, Kidapawan City (15) Brgy. Tagbac, Magpet (16) Brgy. Taluntalunan, Makilala (17) Brgy. San Vicente Makilala (18) Brgy. Balabag, Kidapawan City	

Name of Company in Print

Signature Printed Name of Authorized Representative

Date

Item No	Description	Quantity	Units	Location of Delivery	Delivery Date
Set 2:					
1	Installation Data Logger (Pressure & Flow Reading)	21	units	Refer to Drawings Sheet No. C/15	
2	Installation Data Logger (water level indicator for reservoirs)	21	units	Refer to Drawings Sheet No. C/16	
3	Portable Ultrasonic Flow Meter complete set with	2	units	MKWD Main Office, Brgy. Lanao, Kidapawan City	
4	Portable Water Quality Monitoring Equipment	2	units	MKWD Main Office, Brgy. Lanao, Kidapawan City	
5	Online Water Quality Monitoring Equipment with Data Logger	10	lots	MKWD Main Office, Brgy. Lanao, Kidapawan City	
6	Pumping Station Monitoring System	5	units	Refer to Drawings Sheet No. C/17	
7	Pneumatic Piercing Tool	1	set	MKWD Main Office, Brgy. Lanao, Kidapawan City	
8	Water Meter Calibration Facility Tester Bench Equipment	2	sets	MKWD Manongol Reservoir, Brgy. Manongol, Kidapawan City	
Set 3:					
11	Installation of Central Monitoring Station System Configuration and IT Equipment	1	lot	MKWD Manongol Reservoir, Brgy. Manongol, Kidapawan City	
12	Installation of CCTV Units	12	lots	Refer to Drawings Sheet No. C/18, C/02 to C/14	

 Name of Company in Print

 Signature Printed Name of Authorized Representative

 Date

Section VIII. Technical Specifications

STATE OF COMPLIANCE

Bidders must state in the following form either “Comply” or “Not Comply” against each of the individual parameters of each Specification stating the corresponding performance parameter of the equipment offered. Statements of “Comply” or “Not Comply” must be supported by evidence in a Bidders Bid and cross-referenced to that evidence. Evidence shall be in the form of manufacturer’s un-amended sales literature, unconditional statements of specification and compliance issued by the manufacturer, samples, independent test data etc., as appropriate. A statement that is not supported by evidence or is subsequently found to be contradicted by the evidence presented will render the Bid under evaluation liable for rejection. A statement either in the Bidders statement of compliance or the supporting evidence that is found to be false either during Bid evaluation, post-qualification or the execution of the Contract may be regarded as fraudulent and render the Bidder or supplier liable for prosecution subject to the provisions of **ITB** Clause 3.1(a)(ii) and/or **GCC** Clause 2.1(a)(ii)

No.	Specifications	Statement of Compliance
1	Vertical Multistage Centrifugal Booster Pump – 6 sets <i>(Refer to Section VIII. page 8-25 Booster Pump specifications)</i>	
	Application: Potable Water	
	Capacity: 40 lps (at least)	
	Total Dynamic Head Requirement: 140m	
	Suction Size : 100 mm	
	Motor: 100 HP	
	Bowls Shaft and Impellers : Stainless Steel (AISI 316)	
	Operation: 3 Phase, 3600mp, 220-440 Volts, Automatic Shut-off	
	Pressure Class: PN40	
	<i>Inclusions:</i>	
	Electrical wings and panel board	
	Variable Frequency Drive	
	Adapter Kit	
	Counter Flanges	
	Equipment Installation	
	Free delivery, installation, commissioning, performance testing and product demonstration/training.	
	I. PAYMENT TERMS	
	Payments of Goods shall be in accordance with GCC Clause 10 - Payment of the Bidding Documents.	

(Printed Name and Signature)
Bidder’s Authorized Representative

Date

No.	Specifications	Statement of Compliance
	II. AFTERSALES SALES AND MAINTENANCE	
	1. The External Provider shall have a local service and calibration center based in the Philippines for diagnosis, maintenance and repair of test and measurement instruments. They must provide a list of their service centers.	
	2. Technical support for three (3) years (includes aftersales services and maintenance)	
	3. Customer concerns shall have response within three (3) days upon receipt of notification. Expert technical assistance within one (1) week.	
	III. WARRANTY	
	During the Warranty period, the External Provider upon proper notification of the Procuring Entity shall:	
	1. Send representatives within two (2) calendar days to verify and troubleshoot the issue upon notification. Experts shall arrive within seven (7) calendar days at the site where the defect(s) of Supplies is (are) found to repair or replace;	
	2. Bear all expenses arising from this repair/replacement;	
	3. Must immediately notify the Procuring Entity and/or End-user in case the Supplies cannot be repaired on site;	
	4. Notify the Procuring Entity estimated time for repair/replacement but the period for repair/replacement shall not be longer than five (5) weeks from the dispatch date of the defective and/or damaged items;	
	5. Bear all costs arising from or in connection with the repair and/or replacement, including but not limited to customs duties, taxes and transportation fees;	
	6. Bear all costs arising from and/or in connection with the delay in case the items dispatched for repair/replacement cannot be returned within the stipulated time;	
	7. Extend the warranty period in days, from the day the issue has been reported to the day the repair/replacement has been successfully made, after the verification of the issue. Also, conduct inspection on site of materials/equipment a month before expiration of warranty period.	

 (Printed Name and Signature)
 Bidder's Authorized Representative

 Date

No.	Specifications	Statement of Compliance
2	Generator Set 165 kVA with Auto-Transfer Switch – 6 sets (Refer to Section VIII. page 8-34 for Generating Set specifications)	
	4 Strokes Method Operation	
	22 liters/hour load fuel consumption	
	3 Phase 4 wires connection	
	Closed Circuit Cooling System	
	Silent Type Power (noise level below 75 db @ 7.0m away)	
	Power Factor:	
	<i>Inclusions:</i>	
	Brand New	
	Automatic Transfer Switch	
	Well-Sealed Canopy; Aluminum materials with durable paint coating against corrosion	
	Free delivery, installation, commissioning, performance testing and product demonstration/training.	
	I. PAYMENT TERMS	
	Payments of Goods shall be in accordance with GCC Clause 10 - Payment of the Bidding Documents.	
	II. AFTERSALES SALES AND MAINTENANCE	
	1. The External Provider shall have a local service and calibration center based in the Philippines for diagnosis, maintenance and repair of test and measurement instruments. They must provide a list of their service centers.	
	2. Technical support for three (3) years (includes aftersales services and maintenance)	
	3. Customer concerns shall have response within three (3) days upon receipt of notification. Expert technical assistance within one (1) week.	

 (Printed Name and Signature)
 Bidder's Authorized Representative

 Date

No.	Specifications	Statement of Compliance
	III. WARRANTY	
	During the Warranty period, the External Provider upon proper notification of the Procuring Entity shall:	
	1. Send representatives within two (2) calendar days to verify and troubleshoot the issue upon notification. Experts shall arrive within seven (7) calendar days at the site where the defect(s) of Supplies is (are) found to repair or replace;	
	2. Bear all expenses arising from this repair/replacement;	
	3. Must immediately notify the Procuring Entity and/or End-user in case the Supplies cannot be repaired on site;	
	4. Notify the Procuring Entity estimated time for repair/replacement but the period for repair/replacement shall not be longer than five (5) weeks from the dispatch date of the defective and/or damaged items;	
	5. Bear all costs arising from or in connection with the repair and/or replacement, including but not limited to customs duties, taxes and transportation fees;	
	6. Bear all costs arising from and/or in connection with the delay in case the items dispatched for repair/replacement cannot be returned within the stipulated time;	
	7. Extend the warranty period in days, from the day the issue has been reported to the day the repair/replacement has been successfully made, after the verification of the issue. Also, conduct inspection on site of materials/equipment a month before expiration of warranty period.	
3	Chlorine Gas Feeder w/ Complete Accessory – 6 sets <i>(Refer to Section VIII. page 8-39 Chlorinating Equipment specifications)</i>	
	All accessories should be resilient for gas chemical usage against corrosion.	
	Safety provisions: Installation/Mounting in a reinforced concrete chlorine shed (provision of PPEs and eye wash area on the facility).	
	Includes spare tools fittings:	
	Lead Gasket (250pcs)	
	Chlorine Resistant Tube (50m)	
	Spare Equipment Fittings (2pcs each)	
	Splitter with Regulator	
	Free delivery, installation, commissioning, performance testing and product demonstration/training.	
	I. PAYMENT TERMS	
	Payments of Goods shall be in accordance with GCC Clause 10 - Payment of the Bidding Documents.	

(Printed Name and Signature)
Bidder's Authorized Representative

Date

No.	Specifications	Statement of Compliance
	II. AFTERSALES SALES AND MAINTENANCE	
	1. The External Provider shall have a local service and calibration center based in the Philippines for diagnosis, maintenance and repair of test and measurement instruments. They must provide a list of their service centers.	
	2. Technical support for three (3) years (includes aftersales services and maintenance)	
	3. Customer concerns shall have response within three (3) days upon receipt of notification. Expert technical assistance within one (1) week.	
	III. WARRANTY	
	During the Warranty period, the External Provider upon proper notification of the Procuring Entity shall:	
	1. Send representatives within two (2) calendar days to verify and troubleshoot the issue upon notification. Experts shall arrive within seven (7) calendar days at the site where the defect(s) of Supplies is (are) found to repair or replace;	
	2. Bear all expenses arising from this repair/replacement;	
	3. Must immediately notify the Procuring Entity and/or End-user in case the Supplies cannot be repaired on site;	
	4. Notify the Procuring Entity estimated time for repair/replacement but the period for repair/replacement shall not be longer than five (5) weeks from the dispatch date of the defective and/or damaged items;	
	5. Bear all costs arising from or in connection with the repair and/or replacement, including but not limited to customs duties, taxes and transportation fees;	
	6. Bear all costs arising from and/or in connection with the delay in case the items dispatched for repair/replacement cannot be returned within the stipulated time;	
	7. Extend the warranty period in days, from the day the issue has been reported to the day the repair/replacement has been successfully made, after the verification of the issue. Also, conduct inspection on site of materials/equipment a month before expiration of warranty period.	

(Printed Name and Signature)
Bidder's Authorized Representative

Date

No	Specifications	Statement of Compliance
4	Water Meter Calibration Facility Tester Bench Equipment – 2 sets	
	Inclusions:	
	One (1) set-15-50 Bench (photoelectric liquid level controller included)	
	One (1) piece-Spare filter core	
	Ten (10) pcs.-Slider frame (7pieces small, 3pieces bigger)	
	One (1) set-Flow meter socket	
	One (1) set- Straight pipe (DN15、DN20、DN25、DN32、DN40、DN50)	
	One (10) set-Outlet pipe of flow meter	
	One (10) piece-Photoelectric controller stainless steel base	
	One(1) set-Meter fixing contactor (DN15、DN20、DN25、DN50)	
	Two (2) sets-Screws, nuts	
	One (1) piece- Pressure gauge (0-1.6MPa)	
	One (1) piece- Pressure gauge (0-1 MPa)	
	One (1) piece- Pressure gauge (0-4 MPa)	
	Two (2) pieces-Thermometer (0~50°C)	
	Two (2) pieces-Meter spanner (1small, 1big)	
	One (1) piece-Pressure resistance testing switch	
	One(1) set-DN15、DN20、DN25、DN40、DN50 washer	
	Spare Ø28 washer (40 pcs)	
	Ø33 washer (40 pcs)	
	Ø42 washer (40 pcs)	
	Ø60 washer (40 pcs)	
	Ø20 washer (20 pcs)	
	Ø13 washer (10 pcs)	
	Ø35 washer (4 pcs)	
	Ø40 washer (4 pcs)	
	Ø45 washer (4 pcs)	
	Ø50 washer (4 pcs)	
	Ø60 washer (8 pcs)	
	Ø70 washer (4 pcs)	
	Ø100 washer (4 pcs)	
	Ø115 washer (2 pcs)	
	Ø120 washer (2 pcs)	
	One(1) set w/ 3 pcs-DN15-50 standard vessel (Calibrated by authorized Lab.)	
	Glass pipe for standard vessel-4 pcs.	

(Printed Name and Signature)
Bidder's Authorized Representative

Date

No.	Specifications	Statement of Compliance
	Glass pipe for stabilizing tank-2 pcs.	
	Glass rotor flow meter-7 pcs.	
	One (1) pcs.- 1 cubic meter stabilizing tank	
	One (1) pcs- Water container (2440×1220×450mm)	
	One (1) set-Noiseless Water pump 7.5KW	
	One (1) set-Stainless steel pipe for water circulation loop	
	One (1) piece-Filter	
	Free delivery, installation, commissioning, performance testing and product demonstration/training.	
	I. PAYMENT TERMS	
	Payments of Goods shall be in accordance with GCC Clause 10 - Payment of the Bidding Documents.	
	II. AFTERSALES SALES AND MAINTENANCE	
	1. The External Provider shall have a local service and calibration center based in the Philippines for diagnosis, maintenance and repair of test and measurement instruments. They must provide a list of their service centers.	
	2. Technical support for three (3) years (includes aftersales services and maintenance)	
	3. Customer concerns shall have response within three (3) days upon receipt of notification. Expert technical assistance within one (1) week.	
	III. WARRANTY	
	During the Warranty period, the External Provider upon proper notification of the Procuring Entity shall:	
	1. Send representatives within two (2) calendar days to verify and troubleshoot the issue upon notification. Experts shall arrive within seven (7) calendar days at the site where the defect(s) of Supplies is (are) found to repair or replace;	
	2. Bear all expenses arising from this repair/replacement;	
	3. Must immediately notify the Procuring Entity and/or End-user in case the Supplies cannot be repaired on site;	
	4. Notify the Procuring Entity estimated time for repair/replacement but the period for repair/replacement shall not be longer than five (5) weeks from the dispatch date of the defective and/or damaged items;	
	5. Bear all costs arising from or in connection with the repair and/or replacement, including but not limited to customs duties, taxes and transportation fees;	
	6. Bear all costs arising from and/or in connection with the delay in case the items dispatched for repair/replacement cannot be returned within the stipulated time;	
	7. Extend the warranty period in days, from the day the issue has been reported to the day the repair/replacement has been successfully made, after the verification of the issue. Also, conduct inspection on site of materials/equipment a month before expiration of warranty period.	

 (Printed Name and Signature)
 Bidder's Authorized Representative

 Date

No.	Specifications	Statement of Compliance
5	Installation of Data Logger (Pressure & Flow Reading) – 21 units	
	GENERAL FEATURES:	
	Mechanical design: Screwless opening system for easy access to the SIM card and battery	
	Dimensions: H 261 x W 155 mm	
	Weight : 1.1 kg	
	Operating temperature: -20°C to +55°C	
	Storage temperature: -25°C to +70°C	
	Watertightness: Enhanced IP68 certification (100 days under 1 meter of water)	
	Power supply: Powered by a standard or high capacity internal lithium battery	
	<i>Connector types:</i> Military-grade hermetic connector	
	DATA LOGGER INPUTS:	
	Digital Inputs: 4 digital inputs for standard metering, signaling Maximum frequency: 250 Hz Minimum pulse time: 2 milli-seconds Maximum polarization voltage: 3.3 V Maximum polarization current: 15 µA	
	<i>Analog Inputs:</i> 2 analog inputs for SOFREL pressure sensors or remote powering of third-party sensors Remote powering of third-party sensors via 4-20 mA loop, 12 V or 20 V	
	COMMUNICATION:	
	1. 2G/3G quad-band chipset: Quad-band GSM/GPRS/EDGE (850 MHz, 900 MHz, 1800 MHz, 1900 MHz)Hexa-band UMTS WCDMA FDD (800 MHz (B19), 850 MHz (B5/B6), 900 MHz (B8), 1900 MHz (B2), 2100 MHz (B1))	
	2. Supported SIM cards: Mini SIM cards; Nano and Micro SIM cards can be inserted using an adapter	
	3. Versatile antenna (FLEX version): 4-meters, IP68-certified external antenna	
	4. Automatic data logger synchronization: Communication via SMS with the SCADA: weekly synchronization of the LS via the mobile network; Communication over IP with the SCADA: Daily synchronization of the LS via the SCADA	
	5. Communication with 1 or 2 PCs: Periodic, programmed or event-based	
	6. Inter-sites communication to S500, S4W or AS: Periodic or event-driven (change of DI status or threshold exceedance)*	
	7. Alert transmitted to mobile via SMS: Uponchange in DI state, exceeded threshold, sensor fault.	

(Printed Name and Signature)
Bidder's Authorized Representative

Date

No.	Specifications	Statement of Compliance
	CONFIGURATION AND COMMISSIONING:	
	Bluetooth:Data logger configuration via Bluetooth link	
	Assistance with commissioning: 3G and 2G reception level measurement Best 3G and 2G operator test LEDs for visual diagnosis of operation and 3G/2G signal	
	Assistance with maintenance: Remaining battery life calculator	
	ARCHIVING:	
	Local archiving capacity: 50,000 data points	
	PROCESSING:	
	District metering: Calculation of average flows Calculation of night flows Calculation of daily volumes, daily minimum and maximum flows	
	CERTIFICATIONS:	
	CE Certification: 2014/53/UE “Radio equipment” 2014/30/UE “Electromagnetic compatibility” 2014/35/UE “Low voltage” Enhanced IP68 certification: Extended immersion test (100 days under 1 meter of water) performed by an independent laboratory	
	STANDARD BATTERY LIFE: 2 counts and 1 pressure measurement every 15 minutes, processing and daily transmission to the SCADA - 10 years	
	INCLUSIONS:	
	FTV Server Set - 1 set	
	Laptop/Computer Set - 1 set	
	GSM/GPRS Antenna - 21 sets	
	GSM/GPRS Modem - 21 sets	
	Adaptability to existing flow meters	
	Fabrication of Data Logger Cabinets	
	Equipment Installation and Mounting to existing locations of ultrasonic flow Meters ready for installation	
	Connection wires/cables; Equipment and Software Configuration	
	Free delivery, installation, commissioning, performance testing and product demonstration/training.	
	I. PAYMENT TERMS	
	Payments of Goods shall be in accordance with GCC Clause 10 - Payment of the Bidding Documents.	

(Printed Name and Signature)
Bidder's Authorized Representative

Date

No.	Specifications	Statement of Compliance
	II. AFTERSALES SALES AND MAINTENANCE	
	1. The External Provider shall have a local service and calibration center based in the Philippines for diagnosis, maintenance and repair of test and measurement instruments. They must provide a list of their service centers.	
	2. Technical support for three (3) years (includes aftersales services and maintenance)	
	3. Customer concerns shall have response within three (3) days upon receipt of notification. Expert technical assistance within one (1) week.	
	III. WARRANTY	
	During the Warranty period, the External Provider upon proper notification of the Procuring Entity shall:	
	1. Send representatives within two (2) calendar days to verify and troubleshoot the issue upon notification. Experts shall arrive within seven (7) calendar days at the site where the defect(s) of Supplies is (are) found to repair or replace;	
	2. Bear all expenses arising from this repair/replacement;	
	3. Must immediately notify the Procuring Entity and/or End-user in case the Supplies cannot be repaired on site;	
	4. Notify the Procuring Entity estimated time for repair/replacement but the period for repair/replacement shall not be longer than five (5) weeks from the dispatch date of the defective and/or damaged items;	
	5. Bear all costs arising from or in connection with the repair and/or replacement, including but not limited to customs duties, taxes and transportation fees;	
	6. Bear all costs arising from and/or in connection with the delay in case the items dispatched for repair/replacement cannot be returned within the stipulated time;	
	7. Extend the warranty period in days, from the day the issue has been reported to the day the repair/replacement has been successfully made, after the verification of the issue. Also, conduct inspection on site of materials/equipment a month before expiration of warranty period.	

 (Printed Name and Signature)
 Bidder's Authorized Representative

 Date

No.	Specifications	Statement of Compliance
6	Installation of Data Logger (water level indicator for reservoirs) – 21 units	
	GENERAL FEATURES:	
	Mechanical design: Screwless opening system for easy access to the SIM card and battery	
	Dimensions: H 261 x W 155 mm	
	Weight : 1.1 kg	
	Operating temperature: -20°C to +55°C	
	Storage temperature: -25°C to +70°C	
	Water tightness: Enhanced IP68 certification (100 days under 1 meter of water)	
	Power supply: Powered by a standard or high capacity internal lithium battery	
	<i>Connector types:</i> Military-grade hermetic connector	
	DATA LOGGER INPUTS:	
	Digital Inputs: 4 digital inputs for standard metering, signaling Maximum frequency: 250 Hz Minimum pulse time: 2 ms Maximum polarization voltage: 3.3 V Maximum polarization current: 15 µA	
	<i>Analog Inputs:</i> 2 analog inputs for SOFREL pressure sensors or remote powering of third-party sensors Remote powering of third-party sensors via 4-20 mA loop, 12 V or 20 V	
	US (Ultrasound probe): Ultrasound probe for level measurement, 0-3 meters Dead band: 17 cm Accuracy: +/- 3 mm Resolution: 1 mm Measurement cone: 8° Cable length: 5 or 10 m	
	COMMUNICATION:	
	1. 2G/3G quad-band chipset: Quad-band GSM/GPRS/EDGE (850 MHz, 900 MHz, 1800 MHz, 1900 MHz) Hexa-band UMTS WCDMA FDD (800 MHz (B19), 850 MHz (B5/B6), 900 MHz (B8), 1900 MHz (B2), 2100 MHz (B1))	
	2. Supported SIM cards: Mini SIM cards; Nano and Micro SIM cards can be inserted using an adapter	
	3. Versatile antenna (FLEX version): 4-meters, IP68-certified external antenna	
	4. Automatic data logger synchronization: Communication via SMS with the SCADA: weekly synchronization of the LS via the mobile network; Communication over IP with the SCADA: Daily synchronization of the LS via the SCADA	

(Printed Name and Signature)
Bidder's Authorized Representative

Date

No.	Specifications	Statement of Compliance
	5. Communication with 1 or 2 PCs: Periodic, programmed or event-based	
	6. Inter-sites communication to S500, S4W or AS: Periodic or event-driven (change of DI status or threshold exceedance)*	
	7. Alert transmitted to mobile via SMS: Upon change in DI state, exceeded threshold, sensor fault.	
	CONFIGURATION AND COMMISSIONING:	
	Bluetooth: Data logger configuration via Bluetooth link	
	Assistance with commissioning: 3G and 2G reception level measurement Best 3G and 2G operator test LEDs for visual diagnosis of operation and 3G/2G signal	
	Assistance with maintenance: Remaining battery life calculator	
	ARCHIVING:	
	Local archiving capacity: 50,000 data points	
	Primary and secondary archiving of DI, AI and US probe data: Event-based automatic changing of the archiving period (e.g. overflow)	
	PROCESSING:	
	Self-monitoring: Includes two conversion tables for flow calculations Flow calculation based on measured height Daily calculation of volume linked to flow Calculation of the number of daily overflows	
	STANDARD BATTERY LIFE:	
	Height measurement every 5 minutes 6 years (Daily communication with the SCADA) 10 years (Daily communication with the SCADA)	
	INCLUSIONS:	
	FTV Server Set - 1 set	
	Laptop/Computer Set - 1 set	
	GSM/GPRS Antenna - 21 sets	
	GSM/GPRS Modem - 21 sets	
	Fabrication of Data Logger Cabinets	
	Equipment Installation and Mounting to existing locations of reservoirs Ready for installation	
	Connection wires/cables; Equipment and Software Configuration	
	Free delivery, installation, commissioning, performance testing and product demonstration/training.	
	I. PAYMENT TERMS	
	Payments of Goods shall be in accordance with GCC Clause 10 - Payment of the Bidding Documents.	

(Printed Name and Signature)
Bidder's Authorized Representative

Date

No	Specifications	Statement of Compliance
	II. AFTERSALES SALES AND MAINTENANCE	
	1. The External Provider shall have a local service and calibration center based in the Philippines for diagnosis, maintenance and repair of test and measurement instruments. They must provide a list of their service centers.	
	2. Technical support for three (3) years (includes aftersales services and maintenance)	
	3. Customer concerns shall have response within three (3) days upon receipt of notification. Expert technical assistance within one (1) week.	
	III. WARRANTY	
	During the Warranty period, the External Provider upon proper notification of the Procuring Entity shall:	
	1. Send representatives within two (2) calendar days to verify and troubleshoot the issue upon notification. Experts shall arrive within seven (7) calendar days at the site where the defect(s) of Supplies is (are) found to repair or replace;	
	2. Bear all expenses arising from this repair/replacement;	
	3. Must immediately notify the Procuring Entity and/or End-user in case the Supplies cannot be repaired on site;	
	4. Notify the Procuring Entity estimated time for repair/replacement but the period for repair/replacement shall not be longer than five (5) weeks from the dispatch date of the defective and/or damaged items;	
	5. Bear all costs arising from or in connection with the repair and/or replacement, including but not limited to customs duties, taxes and transportation fees;	
	6. Bear all costs arising from and/or in connection with the delay in case the items dispatched for repair/replacement cannot be returned within the stipulated time;	
	7. Extend the warranty period in days, from the day the issue has been reported to the day the repair/replacement has been successfully made, after the verification of the issue. Also, conduct inspection on site of materials/equipment a month before expiration of warranty period.	
7	Portable Ultrasonic Flow Meter complete set with accessories – 2 units	
	<i>FEATURES:</i>	
	<ul style="list-style-type: none"> • High accuracy + 1.0% of rate and fast response < 1s • With variety detectors • Tolerant to Bubbles • Battery-powered, 12 hours (internal) • Data Storage on SD Card • USB port for connection w/ PC • Displays : Fluid Discharge, Velocity, Accuracy 	

 (Printed Name and Signature)
 Bidder’s Authorized Representative

 Date

No.	Specifications	Statement of Compliance
	<i>Specifications:</i>	
	1.Fluid: Uniform Liquid through which ultrasonic wave can propagate (water, alcohol, etc.)	
	2. Pipe Inner Diameter : 13-6000mm	
	3. Fluid Temperature: -40 to +200 degree Celcius	
	4. Velocity: 0 to ± 32 m/s (minimum ± 0.3 m/s)	
	5. Accuracy: $\pm 1.0\%$ of rate (depends on flow rate)	
	6. Output Cycle: 1s	
	7. 1 path, transmit time method	
	8. Display: Color LCD with Back Light	
	9. Analog Output: 4-20 mA DC (1 point)	
	10. Analog Input: 4-20 mA DC/1-5V DC (2 points)	
	11. Power Supply Voltage: Built in Batter (12 hours continuous operation)	
	12. Enclosure: IP64	
	13. Dimensions : 210x120x65mm	
	14. Wight: 1.0kg (approx.)	
	15. Serial Communication: Data in SD Card can be transmitted to PC; USB Cable: maximum of 3.0 m	
	Functions: *Damping Time (0-100ms) *Instantaneous value display (10 digits) various flow rate unit settable *Total Value Display (10 Digits) Various Flow rate settable *Consumed Heat quantity computation *Self Diagnosis (battery voltage drop and received waveform from the sensor) *Flash memory (parameter of pipe, fluid, sensor,etc) *Number of Registration Sites: 32 *Zero point adjustment (by settling/clearing zero) * Graph View and Waveform view *Bi-directional flow measurement *Low-flow cut-off (0-5m/s)	
	<i>INCLUSIONS:</i>	
	<ul style="list-style-type: none"> • Extra Sensor Cable (1 set for upstream and 1 set for downstream) • Ultrasonic Gel 500mL • 1 unit Laptop (16" Display, At least Core i3 8th Gen Processor) 	
	Free delivery, installation, commissioning, performance testing and product demonstration/training.	

 (Printed Name and Signature)
 Bidder's Authorized Representative

 Date

No.	Specifications	Statement of Compliance
	I. PAYMENT TERMS	
	Payments of Goods shall be in accordance with GCC Clause 10 - Payment of the Bidding Documents.	
	II. AFTERSALES SALES AND MAINTENANCE	
	1. The External Provider shall have a local service and calibration center based in the Philippines for diagnosis, maintenance and repair of test and measurement instruments. They must provide a list of their service centers.	
	2. Technical support for three (3) years (includes aftersales services and maintenance)	
	3. Customer concerns shall have response within three (3) days upon receipt of notification. Expert technical assistance within one (1) week.	
	III. WARRANTY	
	During the Warranty period, the External Provider upon proper notification of the Procuring Entity shall:	
	1. Send representatives within two (2) calendar days to verify and troubleshoot the issue upon notification. Experts shall arrive within seven (7) calendar days at the site where the defect(s) of Supplies is (are) found to repair or replace;	
	2. Bear all expenses arising from this repair/replacement;	
	3. Must immediately notify the Procuring Entity and/or End-user in case the Supplies cannot be repaired on site;	
	4. Notify the Procuring Entity estimated time for repair/replacement but the period for repair/replacement shall not be longer than five (5) weeks from the dispatch date of the defective and/or damaged items;	
	5. Bear all costs arising from or in connection with the repair and/or replacement, including but not limited to customs duties, taxes and transportation fees;	
	6. Bear all costs arising from and/or in connection with the delay in case the items dispatched for repair/replacement cannot be returned within the stipulated time;	
	7. Extend the warranty period in days, from the day the issue has been reported to the day the repair/replacement has been successfully made, after the verification of the issue. Also, conduct inspection on site of materials/equipment a month before expiration of warranty period.	

(Printed Name and Signature)
Bidder's Authorized Representative

Date

	Specifications	Statement of Compliance
8	Portable Water Quality Monitoring Equipment – 2 units	
	<i>FEATURES:</i>	
	High capacity microbiological analysis – dual incubators with independent temperature control for simultaneous determination of up to 40 samples for Thermotolerant or Fecal Coliforms and Total Coliforms	
	Advanced physico-chemical analysis– includes the Photometer 7500, Compact Turbimeter, Palintest Arsenator and electrochemical meters for pH and conductivity/TDS	
	Versatile and flexible – suitable for use in the laboratory, as a makeshift central water laboratory or as an entirely self-contained field kit with independent power	
	Free delivery, installation, commissioning, performance testing and product demonstration/training.	
	I. PAYMENT TERMS	
	Payments of Goods shall be in accordance with GCC Clause 10 - Payment of the Bidding Documents.	
	II. AFTERSALES SALES AND MAINTENANCE	
	1. The External Providers shall have a local service and calibration center based in the Philippines for diagnosis, maintenance and repair of test and measurement instruments. They must provide a list of their service centers.	
	2. Technical support for three (3) years (includes aftersales services and maintenance)	
	3. Customer concerns shall have response within three (3) days upon receipt of notification. Expert technical assistance within one (1) week.	
	III. WARRANTY	
	During the Warranty period, the External Provider upon proper notification of the Procuring Entity shall:	
	1. Send representatives within two (2) calendar days to verify and troubleshoot the issue upon notification. Experts shall arrive within seven (7) calendar days at the site where the defect(s) of Supplies is (are) found to repair or replace;	
	2. Bear all expenses arising from this repair/replacement;	
	3. Must immediately notify the Procuring Entity and/or End-user in case the Supplies cannot be repaired on site;	
	4. Notify the Procuring Entity estimated time for repair/replacement but the period for repair/replacement shall not be longer than five (5) weeks from the dispatch date of the defective and/or damaged items;	
	5. Bear all costs arising from or in connection with the repair and/or replacement, including but not limited to customs duties, taxes and transportation fees;	
	6. Bear all costs arising from and/or in connection with the delay in case the items dispatched for repair/replacement cannot be returned within the stipulated time;	
	7. Extend the warranty period in days, from the day the issue has been reported to the day the repair/replacement has been successfully made, after the verification of the issue. Also, conduct inspection on site of materials/equipment a month before expiration of warranty period.	

 (Printed Name and Signature)
 Bidder's Authorized Representative

 Date

No.	Specifications	Statement of Compliance
9	Online Water Quality Monitoring Equipment with Data Logger - 10 lots	
	FEATURES:	
	Measures water pH, turbidity and temperature and transmit data to main station	
	Can be injected/Install on pressurize/non-pressurize pipelines	
	Free delivery, installation, commissioning, performance testing and product demonstration/training.	
	I. PAYMENT TERMS	
	Payments of Goods shall be in accordance with GCC Clause 10 - Payment of the Bidding Documents.	
	II. AFTERSALES SALES AND MAINTENANCE	
	1. The External Provider shall have a local service and calibration center based in the Philippines for diagnosis, maintenance and repair of test and measurement instruments. They must provide a list of their service centers.	
	2. Technical support for three (3) years (includes aftersales services and maintenance)	
	3. Customer concerns shall have response within three (3) days upon receipt of notification. Expert technical assistance within one (1) week.	
	III. WARRANTY	
	During the Warranty period, the External Provider upon proper notification of the Procuring Entity shall:	
	1. Send representatives within two (2) calendar days to verify and troubleshoot the issue upon notification. Experts shall arrive within seven (7) calendar days at the site where the defect(s) of Supplies is (are) found to repair or replace;	
	2. Bear all expenses arising from this repair/replacement;	
	3. Must immediately notify the Procuring Entity and/or End-user in case the Supplies cannot be repaired on site;	
	4. Notify the Procuring Entity estimated time for repair/replacement but the period for repair/replacement shall not be longer than five (5) weeks from the dispatch date of the defective and/or damaged items;	
	5. Bear all costs arising from or in connection with the repair and/or replacement, including but not limited to customs duties, taxes and transportation fees;	
	6. Bear all costs arising from and/or in connection with the delay in case the items dispatched for repair/replacement cannot be returned within the stipulated time;	
	7. Extend the warranty period in days, from the day the issue has been reported to the day the repair/replacement has been successfully made, after the verification of the issue. Also, conduct inspection on site of materials/equipment a month before expiration of warranty period.	

(Printed Name and Signature)
Bidder's Authorized Representative

Date

No.	Specifications	Statement of Compliance
10	Pumping Station Monitoring System – 5 units	
	FEATURES:	
	Able to independently monitor pumping station on each remote site in real time	
	System monitoring and operation 24/7	
	Send alarm and status from all sites via text message and email	
	INCLUSIONS:	
	Stand alone alarm monitoring controller with 8 digital inputs, 2 analog inputs and 2 relay outputs	
	Outdoor Metal Box/House, with antenna extender, power supply and battery	
	Free delivery, installation, commissioning, performance testing and product demonstration/training.	
	I. PAYMENT TERMS	
	Payments of Goods shall be in accordance with GCC Clause 10 - Payment of the Bidding Documents.	
	II. AFTERSALES SALES AND MAINTENANCE	
	1. The External Provider shall have a local service and calibration center based in the Philippines for diagnosis, maintenance and repair of test and measurement instruments. They must provide a list of their service centers.	
	2. Technical support for three (3) years (includes aftersales services and maintenance)	
	3. Customer concerns shall have response within three (3) days upon receipt of notification. Expert technical assistance within one (1) week.	
	III. WARRANTY	
	During the Warranty period, the External Provider upon proper notification of the Procuring Entity shall:	
	1. Send representatives within two (2) calendar days to verify and troubleshoot the issue upon notification. Experts shall arrive within seven (7) calendar days at the site where the defect(s) of Supplies is (are) found to repair or replace;	
	2. Bear all expenses arising from this repair/replacement;	
	3. Must immediately notify the Procuring Entity and/or End-user in case the Supplies cannot be repaired on site;	

 (Printed Name and Signature)
 Bidder's Authorized Representative

 Date

No.	Specifications	Statement of Compliance
	4. Notify the Procuring Entity estimated time for repair/replacement but the period for repair/replacement shall not be longer than five (5) weeks from the dispatch date of the defective and/or damaged items;	
	5. Bear all costs arising from or in connection with the repair and/or replacement, including but not limited to customs duties, taxes and transportation fees;	
	6. Bear all costs arising from and/or in connection with the delay in case the items dispatched for repair/replacement cannot be returned within the stipulated time;	
	7. Extend the warranty period in days, from the day the issue has been reported to the day the repair/replacement has been successfully made, after the verification of the issue. Also, conduct inspection on site of materials/equipment a month before expiration of warranty period.	
11	Installation of Central Monitoring Station System Configuration and IT Equipment	
	Inclusion: A.)1 set Monitoring Station with equipment	
	A.1) 1 unit -A3 Printer Machine	
	A.2) 1 set- Computer Set (GIS Web Host Server):	
	Specifications: Intel Core i5 2 pcs 8GB RAM total 16GB DDR4 RAM Aerool Rave 80+ Power Supply 600w Server Type System Unit Mother Board Asus Prime 1400VA UPS Server System Unit Type 1 pc 512 SSD with 1 TB HDD Slave Storage 18.5 LED Display Monitor Mouse and Keyboard With Windows Professional Operating System License	
	A.3) 2 units- IP68/69 Android Mobile Device for Geo Tagging	
	Specifications: Shock Proof Dust Proof Water Proof Power Storage Capacity 6000 mah or higher 64 GB storage capacity 4 GB RAM Octa Core Server System Unit Type With 20K mah Power bank Android version 9.0	

 (Printed Name and Signature)
 Bidder's Authorized Representative

 Date

No.	Specifications	Statement of Compliance
	A.4) Wifi Connectivity/Antenna	
	GSM/GPRS Antenna and Modem	
	Internet Connection at Main station for 3 months	
	A.5) Equipment Installation and Mounting	
	B.) Software Configuration	
	Features:	
	Real Time Mobile Data Gathering and Analysis:	
	1. Pressure Reading Data	
	2. Water Level in Storage Tank	
	3. Mobile Maintenance Order Android Application	
	4. Location: View	
	I. PAYMENT TERMS	
	Payments of Goods shall be in accordance with GCC Clause 10 - Payment of the Bidding Documents.	
	II. AFTERSALES SALES AND MAINTENANCE	
	1. The Provider shall have a local service based in the Philippines for diagnosis, maintenance, repair and troubleshooting of TGIS program.	
	2. Technical support for three (3) years (includes aftersales services and maintenance)	
	3. Customer concerns shall have response within two (2) days upon receipt of notification. Expert technical assistance within one (1) week.	
	III. WARRANTY	
	During the Warranty period, the Provider upon proper notification of the Procuring Entity shall:	
	1. Send representatives within two (2) calendar days to verify and troubleshoot the issue upon notification. Experts shall arrive within seven (7) calendar days at the site where the defect(s) of Supplies is (are) found to repair or replace;	
	2. Bear all expenses arising from this repair/replacement;	
	3. Must immediately notify the Procuring Entity and/or End-user in case the Supplies cannot be repaired on site;	
	4. Notify the Procuring Entity estimated time for repair/replacement but the period for repair/replacement shall not be longer than five (5) weeks from the dispatch date of the defective and/or damaged items;	
	5. Bear all costs arising from or in connection with the repair and/or replacement, including but not limited to customs duties, taxes and transportation fees;	

(Printed Name and Signature)
Bidder's Authorized Representative

Date

No.	Specifications	Statement of Compliance
	6. Bear all costs arising from and/or in connection with the delay in case the items dispatched for repair/replacement cannot be returned within the stipulated time;	
	7. Extend the warranty period in days, from the day the issue has been reported to the day the repair/replacement has been successfully made, after the verification of the issue. Also, conduct inspection on site of materials/equipment a month before expiration of warranty period.	
12	CCTV Units – 12 lots	
	Inclusion:	
	1. Wireless Fidelity Connection from Main Control Station to Area	
	2. Real-time viewing at station monitoring area and main control station	
	3. Installation of 26 units HD IP Camera	
	4. Installation of main monitoring room with equipment at MKWD Main Building.	
	Free delivery, installation, commissioning, performance testing and product demonstration/training.	
	I. PAYMENT TERMS	
	Payments of Goods shall be in accordance with GCC Clause 10 - Payment of the Bidding Documents.	
	II. AFTERSALES SALES AND MAINTENANCE	
	1. The Provider shall have a local service and calibration center based in the Philippines for diagnosis, maintenance and repair of test and measurement instruments. They must provide a list of their service centers.	
	2. Technical support for three (3) years (includes aftersales services and maintenance)	
	3. Customer concerns shall have response within three (3) days upon receipt of notification. Expert technical assistance within one (1) week.	
	III. WARRANTY	
	During the Warranty period, the Provider upon proper notification of the Procuring Entity shall:	
	1. Send representatives within two (2) calendar days to verify and troubleshoot the issue upon notification. Experts shall arrive within seven (7) calendar days at the site where the defect(s) of Supplies is (are) found to repair or replace;	
	2. Bear all expenses arising from this repair/replacement;	
	3. Must immediately notify the Procuring Entity and/or End-user in case the Supplies cannot be repaired on site;	
	4. Notify the Procuring Entity estimated time for repair/replacement but the period for repair/replacement shall not be longer than five (5) weeks from the dispatch date of the defective and/or damaged items;	
	5. Bear all costs arising from or in connection with the repair and/or replacement, including but not limited to customs duties, taxes and transportation fees;	

(Printed Name and Signature)
Bidder's Authorized Representative

Date

No.	Specifications	Statement of Compliance
	6. Bear all costs arising from and/or in connection with the delay in case the items dispatched for repair/replacement cannot be returned within the stipulated time;	
	7. Extend the warranty period in days, from the day the issue has been reported to the day the repair/replacement has been successfully made, after the verification of the issue. Also, conduct inspection on site of materials/equipment a month before expiration of warranty period.	
13	Pneumatic Piercing Tool – 1 set	
	Length: 150mm	
	Diameter: 95mm	
	Weight: 54 kg	
	Impact Energy: 150 J	
	Impact Frequency: 5.5 Hz	
	Working pressure-drilling holes (bar): 5.0-6.0	
	Working pressure- work with expander: 6.0-7.0	
	Compressed air consumption (m ³ /min.): 2.3	
	<i>Accessories:</i>	
	Supply air hose 20 meters (1")	
	Compressor air hose 15 meters (1")	
	Oiler 1.3 litre	
	Expanders: 130mm, 146mm, 160mm, 180mm	
	Tension plate and steel rope	
	Pipe ramming cone Ø159mm	
	Aiming tool	
	Starting cradle	
	Water separator	
	Free delivery, installation, commissioning, performance testing and product demonstration/training.	
	I. PAYMENT TERMS	
	Payments of Goods shall be in accordance with GCC Clause 10 - Payment of the Bidding Documents.	
	II. AFTERSALES SALES AND MAINTENANCE	
	1. The External Provider shall have a local service and calibration center based in the Philippines for diagnosis, maintenance and repair of test and measurement instruments. They must provide a list of their service centers.	
	2. Technical support for three (3) years (includes aftersales services and maintenance)	
	3. Customer concerns shall have response within three (3) days upon receipt of notification. Expert technical assistance within one (1) week.	

 (Printed Name and Signature)
 Bidder's Authorized Representative

 Date

No.	Specifications	Statement of Compliance
	III. WARRANTY	
	During the Warranty period, the External Provider upon proper notification of the Procuring Entity shall:	
	1. Send representatives within two (2) calendar days to verify and troubleshoot the issue upon notification. Experts shall arrive within seven (7) calendar days at the site where the defect(s) of Supplies is (are) found to repair or replace;	
	2. Bear all expenses arising from this repair/replacement;	
	3. Must immediately notify the Procuring Entity and/or End-user in case the Supplies cannot be repaired on site;	
	4. Notify the Procuring Entity estimated time for repair/replacement but the period for repair/replacement shall not be longer than five (5) weeks from the dispatch date of the defective and/or damaged items;	
	5. Bear all costs arising from or in connection with the repair and/or replacement, including but not limited to customs duties, taxes and transportation fees;	
	6. Bear all costs arising from and/or in connection with the delay in case the items dispatched for repair/replacement cannot be returned within the stipulated time;	
	7. Extend the warranty period in days, from the day the issue has been reported to the day the repair/replacement has been successfully made, after the verification of the issue. Also, conduct inspection on site of materials/equipment a month before expiration of warranty period.	

 (Printed Name and Signature)
 Bidder's Authorized Representative

 Date

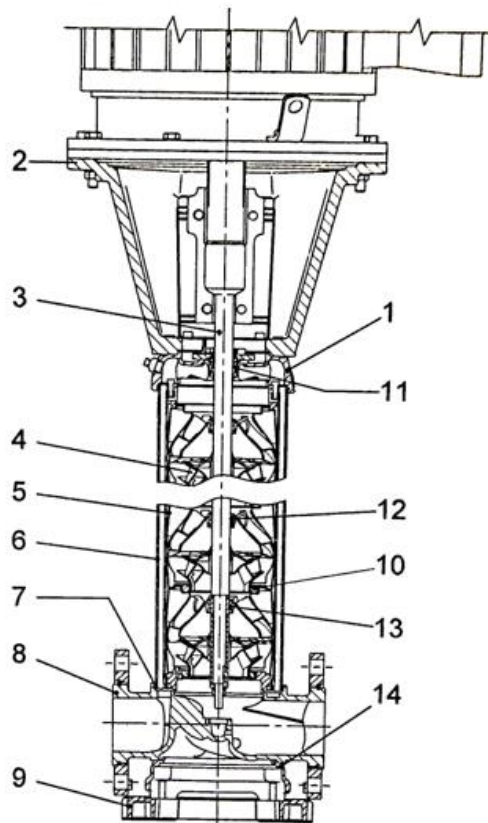
A. 100 HP, VERTICAL CENTRIFUGAL BOOSTER PUMP

<u>Item</u>	<u>Designation</u>	<u>Materials</u>	<u>EN/DIN</u>	<u>AISI/ASTM</u>
1	Pump Head	Stainless Steel	1.4408	A 351 CF 8M
2	Motor Stool	Cast Iron EN-GJS-500-7	EN-JS 1050	A 536 65-45-12
3	Shaft	Stainless Steel	1.4462	SAF 2205
4	Impeller	Stainless Steel	1.4401	AISI 316
5	Chamber	Stainless Steel	1.4401	AISI 316
6	Outer Sleeve	Stainless Steel	1.4401	AISI 316
7	O-Ring for Outer Sleeve	EPDM or FKM		
8	Base	Stainless Steel	1.4408	A 351 CF 8M
9	Base Plate	Cast Iron EN-GJS-500-7	EN-JS 1050	A 536 65-45-12
10	Neck Ring	PTFE		
11	Shaft Seal	Carbon/SiC		
12	Support Bearing	PTFE		
13	Bearing Ring	SiC/SiC		
14	Rubber Parts	EPDM or FKM		

Technical	
Pump speed on which pump data are based	3573 rpm
Rated flow	180 m ³ /h
Rated head	110.4 m
Maximum head	161 m
Stages	4
Impellers	4
Number of reduced-diameter impellers	2
Low NPSH	N
Pump orientation	Vertical
Shaft seal arrangement	Single
Code for shaft seal	HBQV
Approvals on nameplate	CE, EAC
Curve tolerance	ISO9906:2012 3B

Electrical data	
Motor standard	IEC
Motor type	SIEMENS
IE Efficiency class	IE3 - IE2 [NEMA Premium / IE3 60Hz]
Rated power - P2	75 kW [84 kW]
Power (P2) required by pump	75 kW
Mains frequency	60 Hz
Rated voltage	3 x 220-240D/380-420Y V [3 x 255-277D/440-480Y V]
Rated current	235-215/135-122 A [225-207/130-120 A]
Starting current	550-550 % [680-680 %]
Cos phi - power factor	0.90
Rated speed	3570 rpm [3575 rpm]
Efficiency	IE3 94,1% [IE2 94,5%]
Motor efficiency at full load	94.1-94.1 % [94.5-94.5 %]
Motor efficiency at 3/4 load	94.2-94.2 % [94.4-94.4 %]
Motor efficiency at 1/2 load	93.5-93.5 %
Number of poles	2
Enclosure class (IEC 34-5)	55 Dust/Jetting
Insulation class (IEC 85)	F
Motor protec	PTC
Motor No	81U05340

Accessories

- Variable Frequency Drive
- Remote Control
- Control Panel
- Adapter Flange
- Base Plate

B. ELECTRICAL EQUIPMENT

1. SCOPE OF WORK

The Supplier shall furnish, deliver, install, test and commission in accordance with these Specifications and drawings wires and cables, conduits and fittings, motor controller and its auxiliary control devices, grounding system, control transformers, level relay, electrodes and feeder, and other appurtenances as specified herein and shown on the drawings.

2. WIRE AND CABLES

- a. All wires shall be of copper, annealed, soft drawn of 98% conductivity, insulated for 600 V working voltage, type “THHN” or “THWN” insulation unless otherwise noted on the Drawings. Insulation shall bear the manufacturer’s name and trademark, type, voltage, ampere rating and size of the conductor.
- b. Cable for submersible pump operation shall be oil and water-resistant. The cable shall have a minimum of two insulation jackets. The inner jacket shall be of rubber or elasticized rubber material while the outer jacket shall be neoprene PE or PB material. The outer jacket shall bear the manufacture’s name and trademark, insulation type and application, volt and ampere rating and size of the conductor. Cable conductor shall be uncut and unspliced from the motor pigtail to the junction box or terminal for the motor starter. It shall be fixed in place with straps of acceptable materials for such application.

Cable termination to pigtail shall be by means of heavy duty, permanent type splicing kit. Splicing paste shall have a minimum expiration period of one (1) year.

- c. For lighting and power system, no wire smaller than 3.5mm² diameter shall be used. Building wire size 8.0 mm² diameter and larger shall be stranded. Wires for the control system shall be 0.75mm² (18 AWG) minimum, thermoplastic, insulated unless otherwise specified.
- d. Conductor shall not be pulled into the raceway until:
 - 1) raceway system has been inspected.
 - 2) plastering and concrete have been completed in the case of concealed work; and
 - 3) raceway has been freed of moisture and debris.
- e. Conductors shall be hand-pulled using pulling lubricant where necessary.

3. RACEWAY

- a. Conduits for interior system shall be rigid steel or made of uPVC material. Joints of steel conduits cast in concrete shall be made up with a conductive water-proof compounds.
- b. No conduit smaller than 15 mm electrical trade size, nor having more than three 90° bends in any one run shall be used in any system. Bends and offset shall be smooth and symmetrical and shall be accomplished using tools designed for the purpose intended.
- c. The ends of all conduits shall be tightly plugged to exclude plaster, dust and moisture while installation is in progress.
- d. All raceway above ground shall be rigid steel conduit and shall be secured over concrete surfaces, the screws shall be held in place by expansion sleeves. Conduits on exposed works shall be run at right angles to parallel with the surrounding walls; no diagonal runs shall be allowed and all ends and offsets shall be avoided as far as possible. Where necessary, conduits fittings shall be furnished and installed.
- e. Junction boxes and pulled boxes of code gauge steel shall be provided as indicated in the Drawings with suitable fittings to facilitate cable pulling.
- f. Flexible liquid-tight conduit shall be used for connection of equipment such as motor, transformers, flow and pressure switches and other pilot devices. Erickson couplings shall be used at interconnection with rigid conduits.
- g. All conduits installed underground shall be provided with at least 75mm thick concrete envelope.

4. GROUNDING

- a. Ground continuity throughout each facility shall be maintained by installing a electrically continuous raceway system. Metallic raceway shall be installed with double locknuts or hubs at enclosures, non-metallic raceway for branch circuit when specified shall contain copper grounding conductor either bare or insulated. Such conductor shall be bonded to terminal and immediate metallic enclosures. Unless otherwise specified, grounding cables shall be enclosed in conduits and connection shall be made readily accessible for inspection. For pumping station/pump houses, plastic conduits shall not be allowed.
- a. Grounding cables shall be sized in accordance with PEC requirements when not shown on the drawings. Grounding shall be connected to a common grounding rod made of either copper weld or copper-coated steel.

5. SPLICES AND TERMINATIONS

- a. Control conductors shall be spliced or terminated only at the locations indicated on the Drawings and on terminal strips or terminal lugs of vendor-furnished equipment. As used in these Specifications, “control conductors” are defined as conductors that control the electric energy delivered to a power-consuming device.
- b. Branch circuit conductors may be spliced in suitable fittings at locations determined by the Supplier. Conductors shall be spliced or terminated only at equipment shown on the Drawings. Wire in panels, cabinets and gutters shall be neatly grouped using nylon straps and spread out to terminals.
- c. Control conductors shall be terminated under terminal screws with pre-insulated fork tongue lugs or approved equal.
- d. All external control wiring shall end on the internal wiring terminal block on the control console and shall be properly identified or coded to facilitate service and repair.
- e. Splices to motor leads in the motor terminal boxes shall be taped with varnished cambric tape overlapped with a high temperature vinyl tape or approved equal.

6. WIRE AND CABLE IDENTIFICATION

- a. Completed electrical installation shall be provided with adequate identification to facilitate the proper control of circuits and equipment and to reduce maintenance.
- b. Control devices within enclosures shall be identified in accordance with the drawings, identification shall be embossed plastic tape.
- c. General purpose control conductors shall be red. Wire markers shall be plastic impregnated cloth or approved equal.
- d. Control conductor identification legend shall be in accordance with approved shop drawings as well as with the construction drawings. Where these drawings do not state the required identification, the Supplier shall assign numbers. Identification shall be attached within 75mm of the conductor termination. The Supplier may use imprinted plastic, split-sleeve markers cemented together after installation, at his option. Motor control conductors shall be identified at each termination, including intermediate terminal strips.
- e. Terminal strip shall be identified by impregnated varnished marker strip, attached under the terminal strip.

7. CIRCUIT BREAKERS

Circuit breakers shall be molded case type, manually-operated, shall have trip-free operating mechanism of the quick-make, quick-brake type, shall have an earth leakage tripping/ground fault protective device unless otherwise specified. The

circuit breaker shall be of automatic trip type with combination thermal and instantaneous magnetic trip units. Circuit breakers in combination with motor starters shall be of the industrial type with instantaneous magnetic trip, earth leakage/ground fault protective device and provided with standard operating handle mounted on the panel.

The thermal-magnetic time delayed over current protection and instantaneous short circuit protection and instantaneous short circuit protection shall operate a common trip bar which will open all poles in case of overload or short circuit current in any one pole.

The Earth Leakage Tripping Device/Ground Fault Sensor shall operate and interrupt the circuit if the leakage current exceeds its rated sensitivity. Earth leakage tripping device shall eliminate erroneous operations due to rush current produced at the time of starting the motor.

Circuit breaker shall be trip indicating, with tripped position of breaker handle midway between "ON" and "OFF" positions.

8. MOTOR CONTROL EQUIPMENT

a. **GENERAL** - The magnetic starter unit shall consist of soft start/soft stop unit in combination with an industrial type circuit breaker with three overload relays, one for each phase, for motor protection against excessive overloading on starting and in operation. Contactors shall be rated for AC2\AC3 applications according to applicable NEMA or IES standards. Magnetic starter unit shall consist of all necessary relays, timers, and motor protective auxiliary devices against phase failure, dry well/sump and high pressure, among others.

b. COMPONENTS

1) CIRCUIT BREAKERS

Circuit breakers in combination with motor starter shall be of the industrial, molded case type, manually-operated, shall have trip-free operating mechanism of the quick-make, quick-brake type, shall have an earth leakage tripping/ground fault protective device unless otherwise specified. The circuit breaker shall be of automatic trip type with combination thermal and instantaneous magnetic trip units and provided with standard outside operating handle mounted on the panel.

The thermal-magnetic time delayed over current protection and instantaneous short circuit protection and instantaneous short circuit protection shall operate a common trip bar which will open all poles in case of overload or short circuit current in any one pole.

Circuit breaker shall be trip indicating, with tripped position of breaker handle midway between "ON" and "OFF" positions.

2) OVERLOAD RELAY

Overload relay shall conform to IEC 292, IEC 947, NF C 63-650 and VDE 0660. Rated operational insulation voltage shall be according to IEC 292-1, VDE 0110, UL CSA or better. Overload tripping shall be according to UL 508/IEC 947-4 (Class 10) or better. Ambient air temperature for normal operation shall be from -25 to +55°C and ambient temperature shall be from -15 to +55°C.

3) OVERLOAD PROTECTION FOR SUBMERSIBLE PUMP

Overload relay for submersible pump protection shall be of the type with an operating trip response time of 500 milliseconds or less at 100 % trip setting.

4) CIRCUIT DIAGRAM

Laminated control circuit diagram indicating termination numbers on code shall be fastened inside the control unit for ready reference.

5) RELAYS

- a) In general, relays shall be of the electro-mechanical or electronic type suitable for panel mounting and industrial applications. Relay coils shall be rated for continuous operations at 220 volts AC, 60 cps or 48 volts DC as required by their applications. Permissible coil pick-up voltage shall be minus 15% and plus 10% or broader. Drop voltage shall be minus 25% to 40% of rated voltage. Coil burden shall be compatible with each application. Operating temperature shall be minus 5 degrees Centigrade or better. Control relay shall conform to IEC 158-1, 1337 and 225, VDE 0660, or better. Ambient temperature for operation shall be from -40 to +60 degrees Centigrade. Control voltage range shall be from 12 to 600 V. Mechanical life shall be a minimum of 5 million operations. Rated insulation voltage shall conform to VDE 0110C, IEC 158-1, BS 5452 or better.
- b) General application relays shall be instantaneous, non-time delay, of the electro-mechanical or electronic type suitable for panel mounting and industrial applications. Relay action whether closing or opening of the contact shall remain steady until power supply is removed.
- c) Electronic timing relays shall be used where time delay requirements are short duration. These relays shall have a repeat accuracy of plus or minus 10% with adjustable time setting as indicated on the plans or as recommended. Reset time shall be as specified. Timers shall conform to IEC 255-5. Dry ambient temperature for operation shall be from -25 to +55 degree Centigrade. Rated insulation voltage shall be according to IEC 158-1 and VDE 0110. Degree of protection against direct finger contact shall be according to VDE 0106. Reset time shall be 40 milliseconds or less unless otherwise specified.

- d) Motor operated time delay relays shall be used where time delay is three minutes or longer. These relays shall be synchronous with elapsed time indication. Repeat accuracy of relay shall be +2% or less with adjustable time setting as indicated in the Drawings. Automatic resetting shall be upon removal of supply voltage in case delay on energization and upon application of supply voltage in case of time delay in de-energization. For interrupting timing cycles, the timing relay shall reset to its original state without operating the output contact and ready for a new timing cycle. Timer reset shall be specified.
- e) Relay contact shall be 220 volts, 60 hertz rating or 48 volts DC as required by their applications. Continuous current ratings of contacts shall be compatible with the load output requirements and load application, resistive, inductive or motor switching. In case of inductive applications, make and break currents shall also be considered for the kind of load connected. Contact materials shall be silver, good for a mechanical lifetime of 5 million operations. Response time of contact shall be 20 milliseconds or less.
- f) Phase monitor relay shall be provided to protect the system against over/under voltage, single phasing and phase reversal power supply conditions.
- g) Level actuated relay shall be used to actuate reservoir, sump and deepwell water levels to control pump operation at pre-determined high or low level desired.
- h) Relays for use with motor protective devices shall be as required for their intended operations as shown on the Drawings. Relay control sensitivity shall be matched to the specific to be controlled.

6) CONTROL TRANSFORMER

Control transformers shall be of suitable capacity as required by control components, rated 60 Hz, dry-type, two-winding and mounted inside the control panel as shown on the Drawings. Control transformers must be capable of maintaining a high degree of voltage regulation (not less than 95%) from no load to full load through the worst momentary inrush requirements of the control components. It shall have an insulation good for 800°C rise over an ambient of 400°C and a hot temperature of 1500°C with a BIL of 10 kV. Control transformer wiring and termination shall be accessible. The unit shall be manufactured in accordance with U.S. NEMA or IEC Standards.

7) PANEL METERS

- a) Ammeter - The ammeter to be provided shall be of the quadratic panel type with slide-in-dial and shall have minimum dimensions of

70mm x 70mm. Scale range shall be as required for the pumping station load current at system voltage adopted; with a minimum accuracy of plus or minus 2% of full scale. Units for three phase application shall be provided with 3-position selector switch connected to R, S, and T, and three (3) current transformers of suitable rating for each phase while those for single phase shall have an on-off selector switch only.

- b) Voltmeter - The unit shall be quadratic panel type with slide-in-dial and shall have minimum dimensions of 70mm x 70mm. Scale range shall be as required for the system voltage adopted at 60 hertz, with accuracy of plus or minus 2% of the full scale or better. The unit shall be provided with 3-position selector switch connected across RS, RT and ST.

8) **OPERATING HANDLE MECHANISM**

Operating handle for the main circuit breaker shall be designed with the operating handle fitted to the panel door of the control equipment. It shall be used for operating the door and effecting the "ON-TRIP-OFF" operation of the breaker.

It shall be designed such that the door cannot be opened when the breaker is at the "ON" position and shall be provided with a door locking mechanism. A release screw shall be provided to permit the interlock to be cancelled if it is necessary to open the door with the breaker at the "ON" position. Dimensions shall be as recommended by the Manufacturer.

9) **TERMINAL BLOCKS**

Terminal blocks shall be rated 300 volts AC, 60 cps of the molded thermoplastic material. Terminal shall be screw-type, tinned and rated for the maximum continuous current carried among the control components at 75 degree Centigrade temperature rating.

10) **HOUR OPERATION COUNTER**

Hour operation counter (elapsed time meter) shall be rated 220 volts, 60 hertz suitable for panel mounting. Counter shall have six (6) digits hour register, the last digit of which shall indicate tenths of an hour. Hour operation counter shall have square dust-resistant case 65mm each side. Counter shall be non-resetting type.

11) **SELECTOR SWITCH**

Three-position switch, where required, shall have three operating positions; manual, off and automatic. rating of selector switches shall be 220 volts, 60 cps or 48 volts DC as required by its application and with a

current capacity suitable for the type of load connected. They shall be of the thumb-operated pointed type.

12) **PUSH-BUTTON UNITS**

Push-button units shall be standard-duty type, with silver momentary contact-type provided with springs to insure return to their original position. Ratings of push-button units shall be 230 volts, 60 cps or 48 volts DC as required by its application with a current capacity suitable for the type of load connected in series with them. Push-button units shall be concave shape with a minimum diameter of 20mm. Text printed in front of push-button shall indicate its function.

13) **PILOT LAMPS/INDICATORS**

Pilot lamps shall be rated 220 volts, 60 cps or 48 volts DC as required by its application. They shall be clear glass incandescent type.

All pilot lamp indicators shall be designed for front mounting and of a square, round or rectangular type. Text printed on the face of the lamps shall indicate the function of the lamp. Changing of the lamp shall be from the front.

14) **NAMEPLATES**

Nameplates shall be hard plastic material at least 2mm thick. Words as indicated on the plans shall be etched on nameplates in white on a black background. Letters shall be easily readable and in no instance smaller than 10mm in height. Nameplates shall be affixed on control panel by means of flat head screws or glued on.

9. **AUXILIARY PROTECTIVE DEVICES**

The Supplier shall furnish and install all auxiliary motor protective devices intended for their application as shown on the drawings.

a. **PRESSURE SWITCH**

The Supplier shall furnish and install a pressure switch with a range of 0 - 120 psi. The exact setting shall be determined by the engineer in the field, upon testing and commissioning. The switch shall be single pole, single throw Mercoid type DA for indoor/outdoor installation or approved substitute.

C. **DIESEL GENERATING SET**

1. **GENERAL**

- a. The Contractor shall furnish, deliver, install, test and commission of diesel generating sets as required. The generator set shall be mounted on a steel subbase complete with all necessary engine and generator accessories, ready for operation, manually push-button/key start type, rated for continuous power

supply under conditions specified herein. The complete diesel engine generator set shall be free from critical and torsional vibration within the operating speed range.

- b. Tests. The diesel generating set shall receive the manufacturer's standard factory load testing. Test certificates shall be furnished, together with four (4) copies of operation and maintenance manual, including list of recommended spare parts. Supplier's local agent shall supervise during installation. Prior to acceptance of the installation, the equipment shall be tested to show it is free of defect and shall be subjected to full load test, or that load which is available at the job site.
- c. The diesel generating set shall bear the manufacturer's nameplate which shall show:
 - Name of Manufacturer
 - Engine Model Number
 - Engine Rotation
 - Engine Serial Number
 - Standby KW/KVA Rating @ 1800 RPM
 - Power Factor
 - Frequency
 - Year Manufactured

2. DIESEL ENGINE

The engine shall be of the water-cooled, heavy duty, 4-cycle, naturally aspirated or turbocharged, industrial type, equipped with 24 volt DC solenoid engaged electric motor starter and shall develop the full continuous horsepower required by the alternator using diesel fuel when operating at a speed not exceeding 1800 rpm. The engine shall have aluminum pistons, removable type cylinder sleeves, heavy duty replaceable precision type bearings and equipped with vane type oil pump, by-pass oil filter, oil level indicator, a residential type silencer exhaust system.

- a. **STARTER** - The engine shall be equipped with 24 volts DC solenoid engaged electric motor starter.
- b. **LUBRICATING SYSTEM** - The lubricating system shall have a vane type oil pump, a by-pass oil filter, an oil pressure gauge and oil level indicator.
- c. **EXHAUST SYSTEM** - The engine shall be equipped with a residential silencer, sized in accordance with the engine manufacturer's recommendation. Maximum back pressure measured at the exhaust header shall not be more than 350mm (14 in.) of water column. The silencer shall be fabricated of carbon steel designed for 1000°F service and shall be shop painted with silicon base high heat resisting aluminum paint. The silencer shall be installed with flexible metal expansion section of stainless steel and not less than 450mm (18 in.) in length as shown on the Drawings and shall be designed together with all pipes, bends, bolts, nuts and clamps for temperature of not less than 1000°F. The entire exhaust assembly excluding expansion joint shall be insulated with 2-50mm layers of magnesium insulation with lugging as shown on the

drawings.

- d. **FUEL SYSTEM** - The fuel system shall include and injection pump, engine fuel transfer pump, flexible fuel connections, fuel filters and shut-off valves.
 - e. **FUEL OIL STORAGE TANK** - The fuel oil tank shall have a capacity of at least 8 hours of continuous operation and shall come complete with all accessories. Inside surface of the tank shall be pickled or sandblasted to be cleaned of all dust and foreign matter and lightly coated with oil. All tank openings shall be sealed prior to shipping.
 - f. **FUEL LEVEL GAUGE** - The Contractor shall furnish and install a level gauge on the fuel oil tank for visual indication of the amount of fuel remaining on the tank. The gauge shall be either clear glass or plastic materials resistant to normal diesel fuel corrosion. The level gauge shall be provided with valves on both ends for isolation during routine maintenance and replacements. The gauge shall be of appropriate length with graduations calibrated in both in liters and percentage of the total fuel tank capacity.
 - g. **SAFETY SWITCHES** - The engine shall be equipped with safety switches which will cut-off the engine on low oil pressure and high water temperature.
 - h. **BATTERY** - There shall be installed a battery complete with cables for supplying 12 or 24 volts DC power to the engine. The battery shall have the necessary ampere-hour rating for cranking the engine for 10 minutes.
 - i. **BATTERY CHARGER** - The battery charger shall be 12 or 24 volts DC output, 220 volts AC input. It shall have an amperage output sufficient to recharge the battery in 4 hours when the battery is 50% discharge. The charger shall incorporate adjustable float and equalizing voltage potentiometer. A current limit signal shall be supplied in the control circuit from the current sensing resistor. It shall be of the full wave rectifier type and shall include all the required standard components.
3. **MISCELLANEOUS EQUIPMENT** - The engine shall be equipped with the following;
 - a. One (1) intake air cleaner.
 - b. One (1) set of oil lube filters and fuel filters. In addition, the Contractor shall provide three (3) sets of spare oil lube and fuel filters.
 4. **ALTERNATOR**
 - a. The alternator shall be rated for continuous operation at 32 KW (40 KVA), 3-phase, 60 Hz, 1800 rpm, 240 volts, 50°C rise over 30°C ambient temperature at 75M a.s.l. and shall be factory-coupled to the engine. The alternator shall be salient-pole, 12-leads reconnectible, self-ventilated of drip-proof construction with amortisseur windings and skewed stator for smooth voltage waveform. It shall be single bearing, synchronous type with brushless exciter and shall be

built according to applicable NEMA standards. The insulation shall meet the NEMA MG 1-22.40 and 16.40 for class H insulation and shall be further protected with 100% epoxy impregnation and overcoat of resilient insulating material to reduce possible fungus and /or abrasion deterioration per MIL 1-24092. Temperature rise of the rotor shall be limited to NEMA class F ratings.

- b. The excitation system shall be of brushless construction controlled by a solid-state voltage regulator capable of maintaining voltage within +/-2% at any constant load from 0% to 100% of the rating. The regulator must be isolated to prevent tracking when connected to SCR loads, and provide individual adjustments for voltage range, stability and volts-per-hertz operation. The solid state regulator module shall be shock mounted and epoxy encapsulated for protection against vibration and atmospheric deterioration.
- c. Upon one-step application of any load up to 100% of the rated load at .80 PF, the voltage dip shall not exceed 20% and shall recover to +/-2% of the rated voltage within one (1) second.
- d. Alternator shall be capable of sustaining an overload capacity of 300% full load current at zero power factor for a period of ten seconds without damage to it. Output voltage recovery after sudden application or rejection of rated load shall be within 0.3 second.
- e. A resettable line current sensing circuit breaker with inverse time versus current response shall be furnished which protects the generator from damage due to its own high current capability. This breaker shall not trip within ten seconds specified above to allow selective tripping of downstream fuse or circuit breaker under a fault condition. This breaker shall not automatically reset preventing restoration of voltage if maintenance is being performed. Field current-sensing breaker will not be acceptable.
- f. Alternator shall be open, drip-proof construction with an over-all efficiency of at least 85% at full load.
- g. Alternator windings and electrical components shall be tropicalized.
- h. Alternator shall be manufactured by Stamford, Marathon, Onan, Kohler or approved equal.

5. GENERATOR CONTROL PANEL

- a. **GENERAL** - A set mounted alternator/engine control panel shall be supplied with the generator set. The control panel shall be vibration-isolated, dead front construction, 14-gauge steel NEMA 1 enclosure. Cabling and control wiring shall be either side or bottom.
- b. **INSTRUMENT** - Panel shall contain, but not limited to the following equipment.
 - 1) Circuit breaker, thermal-magnetic, industrial type rating as required.

- 2) 1 voltmeter with phase selector switch
- 3) 1 ammeter with phase selector switch and current transformer
- 4) 1 frequency meter
- 5) 1 hour operation counter
- 6) Panel illumination lights and switches
- 7) Indicating relays and fault indicator lamps for low oil pressure, high engine temperature and over speed.
- 8) Engine ammeter
- 9) Engine lube oil pressure gauge
- 10) Engine water temperature gauge
- 11) Tachometer

c. **OPERATING SWITCHES AND PUSHBUTTONS** shall include:

- 1) Manual start/stop pushbuttons/key switch
- 2) Emergency Stop Button
- 3) Control lamp test
- 4) Selector switch
- 5) Test switch

d. **OPERATIONAL CONTROLS** - During operation, the generating set shall be monitored for the following disturbances:

- 1) Loss of lube-oil pressure
- 2) Excess engine temperature
- 3) Alternator overload
- 4) Alternator short circuit
- 5) Overspeed.

Should any of the faults listed under (a) to (e) arises, then the individual signal relay installed for the special task shall respond. To avoid lasting damage if operation were to continue, the generating set shall be

automatically shut-off and a subsequently new starting effort shall be blocked and corresponding fault indicator lamp shall be on.

- e. At protracted overloading of the alternator, the thermal over current release with time delay shall cause the alternator main circuit breaker to trip. The set shall continue in operation unloaded to obtain cooling of the alternator.
- f. In case of feeder short circuit during an emergency supply operation, the alternator shall immediately be disconnected from the fault location by means of the electromagnetic trip relay of the main circuit breaker.

D. CHLORINATING EQUIPMENT

1. Gas Chlorinating Equipment

- a. General – The equipment to be furnished shall be three (3) unit/s of vacuum-operated gas chlorinator/pressure feed type gas chlorinator assembly with pipings and installation details as shown on the drawings and specified herein.
- b. Vacuum-operated Gas Chlorinator
 - 1) The chlorinator shall be of the vacuum operated type with a rated capacity of 5 or 10 pounds of chlorine per day (PPD) and shall operate over 20:1 range with an accuracy of 4% over the specified range. The unit shall be mounted directly on a 150 pound/one (1) ton chlorine cylinder by means of positive yoke type gasketed connection. The vacuum operated chlorinator shall operate satisfactorily over the specified feed range against the maximum back pressure of 30 psi (68.90ft).

The chlorinator shall be provided with the following

- (i) Vacuum regulating valves to isolate gas under pressure from the control system should there be a loss of vacuum.
- (ii) Diaphragm actuated pressure relief valve to prevent the build up of pressure within the gas control system.
- (iii) Gravity actuated indicator directly connected to the main control diaphragm to provide visual signal when the chlorine supply is exhausted or interrupted.
- (iv) An Ejector-diffuser assembly to receive all chlorine and ejector water and discharge the resulting solution at the point of application. The diffuser shall be of the spray type and shall be equipped with check valve to prevent the water from backing up into the chlorinator.
- (v) Accessories-the chlorinator assembly shall be provided with the following:

- 10 ft.-9/4"ejector supply hose
- 25 ft.-3/8"vent and vacuum tubing

60 pcs lead gaskets
2 pcs.-3/4" hose clamps

(vi) Standard spare parts kit which shall include:

For chlorinator

1 set-diaphragm
1 set-all O-rings
1 pc-meter gasket
1 pc-tubing connector
1 pc-inlet filter

For Ejector/Diffuser assembly

1 pc-diaphragm
1 pc-valve set
1 pc-support diaphragm
1 pc-3/8" tubing connector
1 pc-multi-purpose wrench
1 chlorine leak test kit(ammonia)

E. SHOP DRAWINGS AND CATALOG DATA

1. When required, the Contractor shall submit for approval seven (7) copies of the shop drawings of materials and equipment it intends to supply, as indicated in the drawings and specifications.
2. Shop drawings shall provide sufficient information to evaluate the suitability and compliance of the proposed equipment and control components with the plans and specifications.
2. Catalog data shall also be submitted to supplement the shop drawings. Catalog cuts, bulletins, brochures or the like, or photocopies of applicable pages thereof shall be submitted where drawings for certain items are not required to be submitted.

Section IX. Bidding Forms

TABLE OF CONTENTS

Bid Form9-3
For Goods Offered from Abroad9-5
For Goods Offered from within the Philippines9-6
Contract Agreement Form9-7
Omnibus Sworn Statement9-9
Bank Guarantee Form for Advance Payment.....9-12
Bid Securing Declaration Form9-13

Bid Form

Date: _____
 Invitation to Bid No.: WDDSP-MKWD-IFB-G08e

To: **Metro Kidapawan Water District**
 Barangay Lanao, Kidapawan City
 Cotabato

Gentlemen and/or Ladies:

Having examined the Bidding Documents including Bid Bulletin Numbers *[insert numbers]*, the receipt of which is hereby duly acknowledged, we, the undersigned, offer to Supply and Install Various Equipment and Facilities for Lot B- Supply and Installation of Data Loggers, CCTV System and Other Equipment (Set 1-Pumps, Generator Set and Chlorine Gas Feeders and/or Set 2- Data Loggers and Other Equipment and/or Set 3- CCTV and Monitoring Equipment), in conformity with the said Bidding Documents for the sum of *[total Bid amount in words and figures]* or such other sums as may be ascertained in accordance with the Schedule of Prices attached herewith and made part of this Bid.

We undertake, if our Bid is accepted, to deliver the goods in accordance with the delivery schedule specified in the Schedule of Requirements.

If our Bid is accepted, we undertake to provide a performance security in the form, amounts, and within the times specified in the Bidding Documents.

We agree to abide by this Bid for the Bid Validity Period specified in **BDS** provision for **ITB** Clause 18.2 and it shall remain binding upon us and may be accepted at any time before the expiration of that period.

Commissions or gratuities, if any, paid or to be paid by us to agents relating to this Bid, and to contract execution if we are awarded the contract, are listed below:

Name and address of agent	Amount and Currency	Purpose of Commission or gratuity
_____	_____	_____
_____	_____	_____
_____	_____	_____
(if none, state “None”)		

Until a formal Contract is prepared and executed, this Bid, together with your written acceptance thereof and your Notice of Award, shall be binding upon us.

We understand that you are not bound to accept the Lowest Calculated Bid or any Bid you may receive.

We certify/confirm that we comply with the eligibility requirements as per **ITB** Clause 5 of the Bidding Documents.

We likewise certify/confirm that the undersigned, *[for sole proprietorships, insert: as the owner and sole proprietor or authorized representative of Name of Bidder, has the full power and authority to participate, submit the bid, and to sign and execute the ensuing contract, on the latter’s behalf for the Procurement of Supply and Installation of Various Equipment and Facilities for METRO KIDAPAWAN WATER DISTRICT* *[for partnerships, corporations, cooperatives, or joint ventures, insert: is granted full power and authority by the Name of Bidder, to participate, submit the bid, and to sign and execute the ensuing contract on the latter’s behalf for the Procurement of Supply and Installation of Various Equipment and Facilities* LotB- Supply and Installation of Data Loggers, CCTV System and Other Equipment (Set 1-Pumps, Generator Set and Chlorine Gas Feeders and/or Set 2- Data Loggers and Other Equipment and/or Set 3- CCTV and Monitoring Equipment) of METRO KIDAPAWAN WATER DISTRICT

We acknowledge that failure to sign each and every page of this Bid Form, including the attached Schedule of Prices, shall be a ground for the rejection of our bid.

Dated this _____ day of _____ 20_____.

[signature]

[in the capacity of]

Duly authorized to sign Bid for and on behalf of _____

For Goods Offered From Abroad
(Refer to Annex A for the Bid Items to be included here)

Name of Bidder _____ . Invitation to Bid No.: WDDSP-MKWD-
IFB-G08e
 _____ . Page ____ of ____

1	2	3	4	5	6	7	8	9
Item	Description	Country of origin	Quantity	Unit price CIF port of entry (specify port) or CIP named place (specify border point or place of destination)	Total CIF or CIP price per item (col. 4 x 5)	Unit Price Delivered Duty Unpaid (DDU)	Unit price Delivered Duty Paid (DDP)	Total Price delivered DDP (col 4 x 8)

[signature]

[in the capacity of]

Duly authorized to sign Bid for and on behalf of _____

For Goods Offered From Within the Philippines
(Refer to Annex A for the Bid Items to be included here)

Name of Bidder _____, Invitation to Bid No.: WDDSP-MKWD-
IFB-G08e
_____, Page _____ of _____

1	2	3	4	5	6	7	8	9	10
Item	Description	Country of origin	Quantity	Unit price EXW per item	Transportation and Insurance and all other costs incidental to delivery, per item	Sales and other taxes payable if Contract is awarded, per item	Cost of Incidental Services, if applicable, per item	Total Price, per unit (col 5+6+7+8)	Total Price delivered Final Destination (col 9) x (col 4)

[signature]

[in the capacity of]

Duly authorized to sign Bid for and on behalf of _____

For Goods Offered From Abroad
(Refer to Annex B for the Bid Items to be included here)

Name of Bidder _____ Invitation to Bid No.: WDDSP-MKWD-
IFB-G08e
 _____ Page ____ of _____

1	2	3	4	5	6	7	8	9
Item	Description	Country of origin	Quantity	Unit price CIF port of entry (specify port) or CIP named place (specify border point or place of destination)	Total CIF or CIP price per item (col. 4 x 5)	Unit Price Delivered Duty Unpaid (DDU)	Unit price Delivered Duty Paid (DDP)	Total Price delivered DDP (col 4 x 8)

_____ *[signature]* _____ *[in the capacity of]*

Duly authorized to sign Bid for and on behalf of _____

For Goods Offered From Within the Philippines
(Refer to Annex B for the Bid Items to be included here)

Name of Bidder _____, Invitation to Bid No.: WDDSP-MKWD-
IFB-G08e
_____. Page _____ of _____

1	2	3	4	5	6	7	8	9	10
Item	Description	Country of origin	Quantity	Unit price EXW per item	Transportation and Insurance and all other costs incidental to delivery, per item	Sales and other taxes payable if Contract is awarded, per item	Cost of Incidental Services, if applicable, per item	Total Price, per unit (col 5+6+7+8)	Total Price delivered Final Destination (col 9) x (col 4)

[signature]

[in the capacity of]

Duly authorized to sign Bid for and on behalf of _____

For Goods Offered From Abroad
(Refer to Annex C for the Bid Items to be included here)

Name of Bidder _____ Invitation to Bid No.: WDDSP-MKWD-IFB-G08e
 _____ Page ____ of ____

1	2	3	4	5	6	7	8	9
Item	Description	Country of origin	Quantity	Unit price CIF port of entry (specify port) or CIP named place (specify border point or place of destination)	Total CIF or CIP price per item (col. 4 x 5)	Unit Price Delivered Duty Unpaid (DDU)	Unit price Delivered Duty Paid (DDP)	Total Price delivered DDP (col 4 x 8)

[signature]

[in the capacity of]

Duly authorized to sign Bid for and on behalf of _____

For Goods Offered From Within the Philippines
(Refer to Annex C for the Bid Items to be included here)

Name of Bidder _____, Invitation to Bid No.: WDDSP-MKWD-
 _____, IFB-G08e
 Page _____ of _____

1	2	3	4	5	6	7	8	9	10
Item	Description	Country of origin	Quantity	Unit price EXW per item	Transportation and Insurance and all other costs incidental to delivery, per item	Sales and other taxes payable if Contract is awarded, per item	Cost of Incidental Services, if applicable, per item	Total Price, per unit (col 5+6+7+8)	Total Price delivered Final Destination (col 9) x (col 4)

[signature]

[in the capacity of]

Duly authorized to sign Bid for and on behalf of _____

Contract Agreement Form

THIS AGREEMENT made the ____ day of _____ 2020____ between METRO KIDAPAWAN WATER DISTRICT of the Philippines (hereinafter called “the Entity”) of the one part and [name of Supplier] of [city and country of Supplier] (hereinafter called “the Supplier”) of the other part:

WHEREAS the Entity invited Bids for certain goods and ancillary services, viz **Procurement of Supply and Installation of Various Equipment and Facilities** Lot B- Supply and Installation of Data Loggers, CCTV System and Other Equipment (Set 1-Pumps, Generator Set and Chlorine Gas Feeders, Set 2- Data Loggers and Other Equipment and Set 3- CCTV and Monitoring Equipment) and has accepted a Bid by the Supplier for the supply of those goods and services in the sum of [contract price in words and figures] (hereinafter called “the Contract Price”).

NOW THIS AGREEMENT WITNESSETH AS FOLLOWS:

1. In this Agreement words and expressions shall have the same meanings as are respectively assigned to them in the Conditions of Contract referred to.
2. The following documents shall be deemed to form and be read and construed as part of this Agreement, viz.:
 - (a) the Supplier’s Bid, including the Technical and Financial Proposals, and all other documents/statements submitted (e.g. bidder’s response to clarifications on the bid), including corrections to the bid resulting from the Procuring Entity’s bid evaluation;
 - (b) the Schedule of Requirements;
 - (c) the Technical Specifications;
 - (d) the General Conditions of Contract;
 - (e) the Special Conditions of Contract;
 - (f) the Performance Security; and
 - (g) the Entity’s Notice of Award.
3. In consideration of the payments to be made by the Entity to the Supplier as hereinafter mentioned, the Supplier hereby covenants with the Entity to provide the goods and services and to remedy defects therein in conformity in all respects with the provisions of the Contract
4. The Entity hereby covenants to pay the Supplier in consideration of the provision of the goods and services and the remedying of defects therein, the Contract Price or such other sum as may become payable under the provisions of the contract at the time and in the manner prescribed by the contract.

IN WITNESS whereof the parties hereto have caused this Agreement to be executed in accordance with the laws of the Republic of the Philippines on the day and year first above written.

Signed, sealed, delivered by _____ the _____ (for the Entity)

Signed, sealed, delivered by _____ the _____ (for the Supplier).

Omnibus Sworn Statement

REPUBLIC OF THE PHILIPPINES)
CITY/MUNICIPALITY OF _____) S.S.

AFFIDAVIT

I, *[Name of Affiant]*, of legal age, *[Civil Status]*, *[Nationality]*, and residing at *[Address of Affiant]*, after having been duly sworn in accordance with law, do hereby depose and state that:

1. **Select one, delete the other:**

If a sole proprietorship: I am the sole proprietor or authorized representative of *[Name of Bidder]* with office address at *[address of Bidder]*;

If a partnership, corporation, cooperative, or joint venture: I am the duly authorized and designated representative of *[Name of Bidder]* with office address at *[address of Bidder]*;

2. **Select one, delete the other:**

If a sole proprietorship: As the owner and sole proprietor, or authorized representative of *[Name of Bidder]*, I have full power and authority to do, execute and perform any and all acts necessary to participate, submit the bid, and to sign and execute the ensuing contract for *[Name of the Project]* of the *[Name of the Procuring Entity]*, as shown in the attached duly notarized *Special Power of Attorney*;

If a partnership, corporation, cooperative, or joint venture: I am granted full power and authority to do, execute and perform any and all acts necessary to participate, submit the bid, and to sign and execute the ensuing contract for *[Name of the Project]* of the *[Name of the Procuring Entity]*, as shown in the attached *[state title of attached document showing proof of authorization (e.g., duly notarized Secretary's Certificate, Board/Partnership Resolution, or Special Power of Attorney, whichever is applicable)]*;

3. *[Name of Bidder]* is not “blacklisted” or barred from bidding by the Government of the Philippines or any of its agencies, offices, corporations, or Local Government Units, foreign government/foreign or international financing institution whose blacklisting rules have been recognized by the Government Procurement Policy Board;
4. Each of the documents submitted in satisfaction of the bidding requirements is an authentic copy of the original, complete, and all statements and information provided therein are true and correct;
5. *[Name of Bidder]* is authorizing the Head of the Procuring Entity or its duly authorized representative(s) to verify all the documents submitted;

6. **Select one, delete the rest:**

If a sole proprietorship: The owner or sole proprietor is not related to the Head of the Procuring Entity, members of the Bids and Awards Committee (BAC), the Technical Working Group, and the BAC Secretariat, the head of the Project Management Office or the end-user unit, and the project consultants by consanguinity or affinity up to the third civil degree;

If a partnership or cooperative: None of the officers and members of [Name of Bidder] is related to the Head of the Procuring Entity, members of the Bids and Awards Committee (BAC), the Technical Working Group, and the BAC Secretariat, the head of the Project Management Office or the end-user unit, and the project consultants by consanguinity or affinity up to the third civil degree;

If a corporation or joint venture: None of the officers, directors, and controlling stockholders of [Name of Bidder] is related to the Head of the Procuring Entity, members of the Bids and Awards Committee (BAC), the Technical Working Group, and the BAC Secretariat, the head of the Project Management Office or the end-user unit, and the project consultants by consanguinity or affinity up to the third civil degree;

7. [Name of Bidder] complies with existing labor laws and standards; and
8. [Name of Bidder] is aware of and has undertaken the following responsibilities as a Bidder:
- a) Carefully examine all of the Bidding Documents;
 - b) Acknowledge all conditions, local or otherwise, affecting the implementation of the Contract;
 - c) Made an estimate of the facilities available and needed for the contract to be bid, if any; and
 - d) Inquire or secure Supplemental/Bid Bulletin(s) issued for the [Name of the Project].
9. [Name of Bidder] did not give or pay directly or indirectly, any commission, amount, fee, or any form of consideration, pecuniary or otherwise, to any person or official, personnel or representative of the government in relation to any procurement project or activity.

IN WITNESS WHEREOF, I have hereunto set my hand this ___ day of ___, 20__ at _____, Philippines.

Bidder's Representative/Authorized Signatory

SUBSCRIBED AND SWORN to before me this ____ day of [month] [year] at [place of execution], Philippines. Affiant/s is/are personally known to me and was/were identified by me through competent evidence of identity as defined in the 2004 Rules on Notarial Practice (A.M. No. 02-8-13-SC). Affiant/s exhibited to me his/her [insert type of government identification card used], with his/her photograph and signature appearing thereon, with no. _____ and his/her Community Tax Certificate No. _____ issued on ____ at _____.

Witness my hand and seal this ____ day of [month] [year].

NAME OF NOTARY PUBLIC

Serial No. of Commission _____

Notary Public for _____ until _____

Roll of Attorneys No. _____

PTR No. _____ [date issued], [place issued]

IBP No. _____ [date issued], [place issued]

Doc. No. _____

Page No. _____

Book No. _____

Series of _____

Bank Guarantee Form for Advance Payment

(For Goods Offered from Abroad)

To: **Metro Kidapawan Water District**
Barangay Lanao, Kidapawan City
Cotabato

Procurement of Supply and Installation of Various Equipment and Facilities

Lot B- Supply and Installation of Data Loggers, CCTV System and Other Equipment (Set 1- Pumps, Generator Set and Chlorine Gas Feeders, Set 2- Data Loggers and Other Equipment and Set 3- CCTV and Monitoring Equipment)

Gentlemen and/or Ladies:

In accordance with the payment provision included in the Special Conditions of Contract, which amends Clause 10 of the General Conditions of Contract to provide for advance payment, *[name and address of Supplier]* (hereinafter called the “Supplier”) shall deposit with the METRO KIDAPAWAN WATER DISTRICT a bank guarantee to guarantee its proper and faithful performance under the said Clause of the Contract in an amount of *[amount of guarantee in figures and words]*.

We, the *[bank or financial institution]*, as instructed by the Supplier, agree unconditionally and irrevocably to guarantee as primary obligator and not as surety merely, the payment to the METRO KIDAPAWAN WATER DISTRICT on its first demand without whatsoever right of objection on our part and without its first claim to the Supplier, in the amount not exceeding *[amount of guarantee in figures and words]*.

We further agree that no change or addition to or other modification of the terms of the Contract to be performed thereunder or of any of the Contract documents which may be made between the METRO KIDAPAWAN WATER DISTRICT and the Supplier, shall in any way release us from any liability under this guarantee, and we hereby waive notice of any such change, addition, or modification.

This guarantee shall remain valid and in full effect from the date of the advance payment received by the Supplier under the Contract until *[date]*.

Yours truly,

Signature and seal of the Guarantors

[name of bank or financial institution]

[address]

[date]

BID SECURING DECLARATION FORM
(If required)

REPUBLIC OF THE PHILIPPINES)
CITY OF _____) S.S.

X-----X

BID SECURING DECLARATION
Invitation to Bid: WDDSP-MKWD-IFB-G08e

To: **Metro Kidapawan Water District**
Barangay Lanao, Kidapawan City
Cotabato

I/We¹, the undersigned, declare that:

1. I/We understand that, according to your conditions, bids must be supported by a Bid Security, which may be in the form of a Bid-Securing Declaration.
2. I/We accept that: (a) I/we will be automatically disqualified from bidding for any contract with any procuring entity for a period of two (2) years upon receipt of your Blacklisting order; and, (b) I/we will pay the applicable fine provided under Section 6 of the Guidelines on the Use of Bid Securing Declaration, within fifteen (15) days from receipt of the written demand by the procuring entity for the commission of acts resulting to the enforcement of the bid securing declaration under Sections 23.1(b), 34.2, 40.1 and 69.1, except 69.1(f), of the IRR of RA 9184; without prejudice to other legal action the government may undertake.
3. I/We understand that this BidSecuring Declaration shall cease to be valid on the following circumstances:
 - (a) Upon expiration of the bid validity period, or any extension thereof pursuant to your request;
 - (b) I am/we are declared ineligible or post-disqualified upon receipt of your notice to such effect, and (i) I/we failed to timely file a request for reconsideration or (ii) I/we filed a waiver to avail of said right;

¹ Select one and delete the other. Adopt the same instruction for similar terms throughout the document.

- (c) I am/we are declared the bidder with the Lowest Calculated Responsive Bid, and I/we have furnished the performance security and signed the Contract.

IN WITNESS WHEREOF, I/We have hereunto set my/our hand/s this ____ day of [month] [year] at [place of execution].

[Insert NAME OF BIDDER'S AUTHORIZED REPRESENTATIVE]
[Insert Signatory's Legal Capacity]
 Affiant

SUBSCRIBED AND SWORN to before me this ____ day of [month] [year] at [place of execution], Philippines. Affiant/s is/are personally known to me and was/were identified by me through competent evidence of identity as defined in the 2004 Rules on Notarial Practice (A.M. No. 02-8-13-SC). Affiant/s exhibited to me his/her [insert type of government identification card used], with his/her photograph and signature appearing thereon, with no. _____ and his/her Community Tax Certificate No. _____ issued on ____ at _____.

Witness my hand and seal this ____ day of [month] [year].

NAME OF NOTARY PUBLIC
 Serial No. of Commission _____
 Notary Public for _____ until _____
 Roll of Attorneys No. _____
 PTR No. _____ [date issued], [place issued]
 IBP No. _____ [date issued], [place issued]

Doc. No. _____
 Page No. _____
 Book No. _____
 Series of _____



METRO KIDAPAWAN WATER DISTRICT
 Lanao, Kidapawan City
 Tel nos. (064)577-1533, 577-1865, Fax no. (064) 572-5555
 E-mail Address: metrokidapawan_wd@yahoo.com
 Website: www.metrokidapawanwd.gov.ph
“Committed to Service, Development and Self-Reliance”



ISO 9001:2015 Certified
 Cert. No. 66478
 ISO 9001:2015 Certified
 Cert. No. 66478

ANNEX A. BILL OF QUANTITIES WITH UNIT BID PRICES AND TOTAL BID PRICES SET1

1 Item No.	2 Description	3 Quantity	4 Unit	5 Unit Price (Php)	6 Total Bid Price (Php)
1	Vertical Multistage Centrifugal Booster Pump	6	sets		
2	Generator Set 165kVA with Auto-Transfer Switch	6	sets		
3	Chlorine Gas Feeder w/ Complete Accessory	6	sets		

Bid Validity: _____

Name and Signature of Bidder:

Address:

Contact Number:

Name and Signature of Representative:

Notes: Columns 1 to 4 to be filled up by the Procuring Entity.
 Columns 5 to 6 to be filled up by the Bidder



METRO KIDAPAWAN WATER DISTRICT
 Lanao, Kidapawan City
 Tel nos. (064)577-1533, 577-1865, Fax no. (064) 572-5555
 E-mail Address: metrokidapawan_wd@yahoo.com
 Website: www.metrokidapawan.gov.ph
“Committed to Service, Development and Self-Reliance”



ISO 9001:2015 Certified
 Cert. No. 66478
 ISO 9001:2015 Certified
 Cert. No. 66478

ANNEX B. BILL OF QUANTITIES WITH UNIT BID PRICES AND TOTAL BID PRICES SET2

1	2	3	4	5	6
Item No.	Description	Quantity	Unit	Unit Price (Php)	Total Bid Price (Php)
1	Installation of Data Logger (Pressure & Flow Reading)	21	units		
2	Installation of Data Logger (Water level indicator for reservoirs)	21	units		
3	Portable Ultrasonic Flow Meter complete set with	2	units		
4	Portable Water Quality Monitoring Equipment	2	units		
5	Online Water Quality Monitoring Equipment with Data Logger	10	lots		
6	Pumping Station Monitoring System	5	units		
7	Pneumatic Piercing Tool	1	set		
8	Water Meter Calibration Facility Tester Bench Equipment	2	sets		

Bid Validity: _____

Name and Signature of Bidder:

Address:

Contact Number:

Name and Signature of Representative:

Notes: Columns 1 to 4 to be filled up by the Procuring Entity
 Columns 5 to 6 to be filled up by the Bidder



METRO KIDAPAWAN WATER DISTRICT
 Lanao, Kidapawan City
 Tel nos. (064)577-1533, 577-1865, Fax no. (064) 572-5555
 E-mail Address: metrokidapawan_wd@yahoo.com
 Website: www.metrokidapawanwd.gov.ph
 “Committed to Service, Development and Self-Reliance”



ISO 9001:2015 Certified
 Cert. No. 66478
 ISO 9001:2015 Certified
 Cert. No. 66478

ANNEX C. BILL OF QUANTITIES WITH UNIT BID PRICES AND TOTAL BID PRICES SET 3

1	2	3	4	5	6
Item No.	Description	Quantity	Unit	Unit Price (Php)	Total Bid Price (Php)
1	Installation of Central Monitoring Station System Configuration and IT Equipment	1	lot		
2	Installation of CCTV Units	12	lots		

Bid Validity: _____

Name and Signature of Bidder:

Address:

Contact Number:

Name and Signature of Representative:

Notes: Columns 1 to 4 to be filled up by the Procuring Entity
 Columns 5 to 6 to be filled up by the Bidder

